

**Catálogo de  
Aplicações**

**2010**







## LEGENDAS



CÓDIGO PINGUIM



PADRÃO

PADRÃO DE CONSTRUÇÃO  
EM RELAÇÃO À PEÇA ORIGINAL



PERÍODO DE FABRICAÇÃO  
DO VEÍCULO OU EQUIPAMENTO



A x L

DIMENSÕES DA COLMÉIA



Nº ORIGINAL

Nº DA PEÇA DO FABRICANTE ORIGINAL  
DO VEÍCULO OU EQUIPAMENTO



CONSTR.

TIPO DE CONSTRUÇÃO DA  
COLMÉIA



VEÍCULO OU EQUIPAMENTO



CAB.

ESPECIFICAÇÃO DE CABECEIRA

Os produtos apresentados nesse catálogo poderão sofrer alteração em sua construção sem aviso prévio.

## TIPOS DE CONSTRUÇÃO

**TBE**

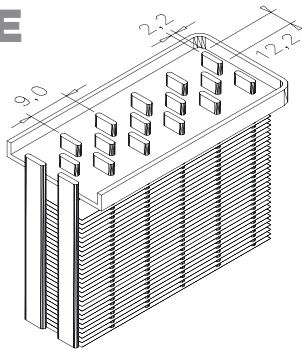

**TBG**

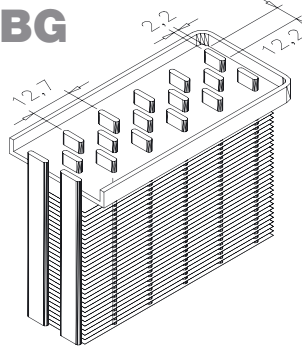

**TBL**

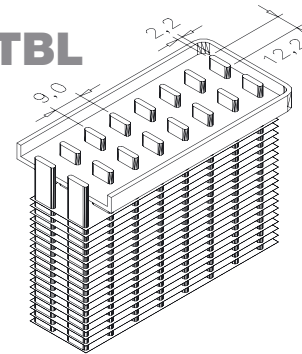

**TBC**

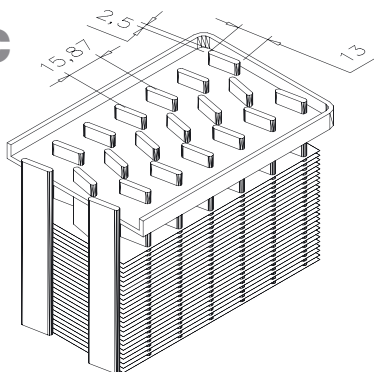

**CTM**

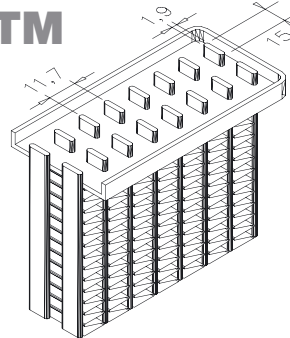

**CTY**

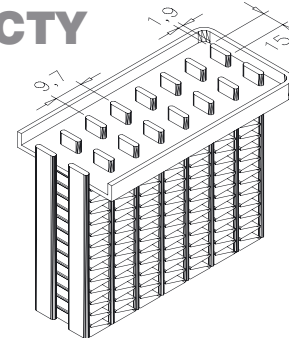

**AL**

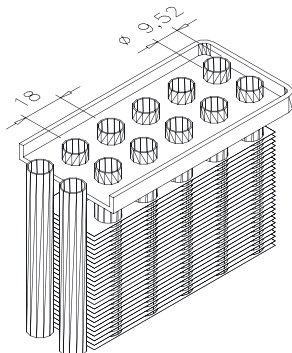

**TCU**

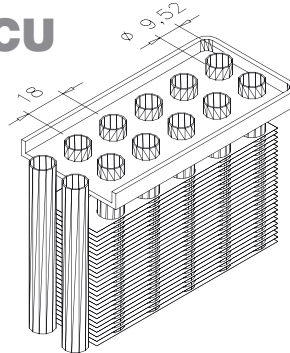

## COMO SOLICITAR UMA COLMÉIA SOB MEDIDA

### ENTREGAMOS COLMÉIAS SOB MEDIDA EM 24HS

Existem 2 tipos de radiadores - com fluxo horizontal (figura 1) que trabalha deitado e com fluxo vertical (figura 2) que trabalha em pé.

Figura 1



Figura 2



- **ALTURA:** É a medida entre cabeceiras (sentido do comprimento dos tubos).
- **LARGURA:** É a distância entre as laterais.
- **ESPESSURA:** Varia de acordo com o tipo de construção do bloco e a quantidade de carreiras de tubos (figura 3).
- **CABECEIRAS:** São as bases em que são soldados os tanques (caixas) do radiador. Existem 2 medidas principais: o comprimento e a largura.
- **ALETAS:** Podem ser do tipo plana (TBE, TBG, TBL e TBC) ou zig-zag (CTM e CTY) e o número de aletas é determinado por polegada linear (figura 5).

Figura 3

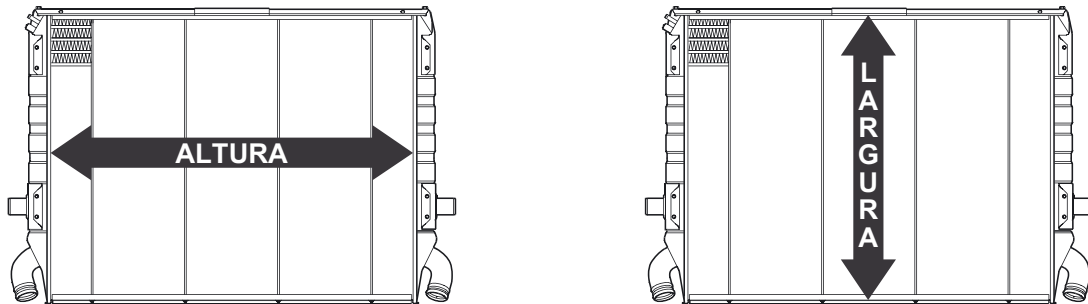
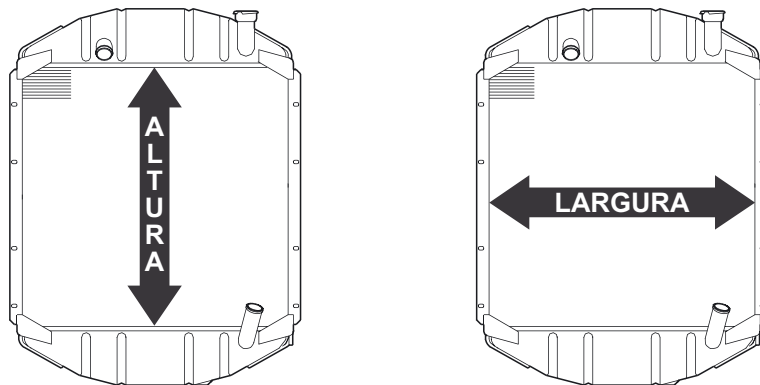

Figura 4



Figura 5

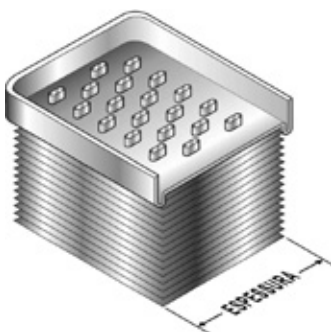

# ÍNDICE

---

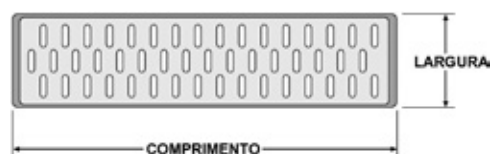
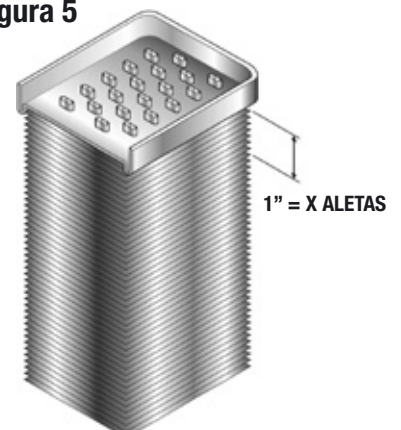
AGRALE .....	PAG 01
ASIA.....	PAG 01
CBT .....	PAG 02
CAMECO / SLC JOHN DEERE.....	PAG 02
CASE .....	PAG 03
CATERPILLAR .....	PAG 04 / 05 / 06
CLARK .....	PAG 06
CUMMINS.....	PAG 06
DODGE.....	PAG 06
FIAT .....	PAG 07
FIAT ALLIS.....	PAG 07
FORD .....	PAG 08 / 09 / 10
FORD NEW HOLLAND .....	PAG 11
GM .....	PAG 12
HYSTER.....	PAG 13
HYUNDAI .....	PAG 13
IDEAL.....	PAG 13
IVECO.....	PAG 14
KIA.....	PAG 14
KOMATSU.....	PAG 15
MWM.....	PAG 15 / 16
MF (AGCO) .....	PAG 16
MBB.....	PAG 17 / 18 / 19 / 20 / 21
MICHIGAN .....	PAG 22
mitsubishi .....	PAG 22
NISSAN .....	PAG 22
PERKINS.....	PAG 22
PEUGEOT .....	PAG 23
RENAULT .....	PAG 23
SCANIA .....	PAG 23 / 24 / 25
TEREX.....	PAG 25
TOYOTA.....	PAG 25 / 26
VW.....	PAG 26 / 27 / 28
VALMET - VALTRA.....	PAG 29
VOLVO.....	PAG 30
YALE .....	PAG 31
YANMAR.....	PAG 31

---





## AGRALE - COLMÉIAS

		TIPO		PADRÃO			CONSTR.	CAB.
CP14018 CP14056	CTM CTM	MA 7.5 TCA / MA 8.5 TCA Volare A6 / A8 / 6000 D / Volare / Cargo 6000		Original Especial	440 623	2 CTM 14 3 CTM 14		65 X 640
CP24007	TBE	1600		Original	460 500	3 TBE 8		
CP24004 CP24005	TBE TBE	1600		Original Especial	465 445	3 TBE 8 4 TBE 8		
CP24001 CP24002	CTM CTM	4500 D / 1800 D / 5000 D / 7000 D / 7500 TD 7500 TDX / 7000 DX / 8500 / MA 7.0 TD / MA 7.5T / MA 8.5 T		Original Especial	475 488	2 CTM 14 3 CTM 14		
CP24006 CP24008	TBE TBE	1800		Especial Original	480 530	4 TBE 8 3 TBE 8		
CP24009	TBE	7000 / 7500		Original	485 500	3 TBE 8		
CP14047 CP14057	CTY CTM	Micro Ônibus MWM / W8		Original Especial	500 623	2 CTY 16 3 CTM 14		65 X 640

## ÁSIA - COLMÉIAS

		TIPO		PADRÃO			CONSTR.	
CP24410 CP24411	TBE TBE	Towner Coach - Furgão		Econômico Original	305 300	3 TBE 8 3 TBE 11		Todos
CP24417 CP24419	TBE	Towner Rio		Econômico Original	320 300	3 TBE 8 3 TBE 11		Todos
CP24412 CP24413	TBE TBE	Towner Truck - Pick-up		Econômico Original	365 325	3 TBE 8 3 TBE 11		Todos
CP24418 CP24416 CP24420	TBE TBE TBE	Topic 2.7		Original Especial Econômico	370	540	3 TBE 11 4 TBE 8 3 TBE 8	96 / 99
CP24414 CP24415	TBE TBE	Topic 2.7		Original Especial	374 490	4 TBE 8 4 TBE 11		> 95

## ÁSIA - RADIADORES

		TIPO		NÚMERO ORIGINAL	PADRÃO			CONSTR.	
RP24411	TBE	Towner Coach - Furgão		AA.110.15200.F	Original	305 300	3 TBE 11		Todos
RP24413	TBE	Towner Truck - Pick-up		AA.110.15200.E	Original	365 325	3 TBE 11		Todos
RP24418	TBE	Topic 2.7		AA.76A.15200	Original	370 540	3 TBE 11		96 / 99
RP24414	TBE	Topic 2.7		AA.70A.15200.B / AA.70B.15200.B	Original	374 490	4 TBE 8		> 95



## CBT - COLMÉIAS

		TIPO		PADRÃO		CONSTR.	CAB.
CP22000	TBE	1000		Original	440	400	3 TBE 8 Abaulada
CP22001	TBE	2070		Original	488	400	3 TBE 8 4 TBE 8 Abaulada
CP22002	TBE	1065 / 2080		Original	494	400	4 TBE 8 Abaulada
CP20006	TBE	8240 / 8440		Original	494	400	4 TBE 8 Abaulada
CP20005	TBG	1090 / 1105 / 2100 / 2500 / 2600 / 8260		Opcional	570	510	5 TBG 8
CP20004	TBE			Original			5 TBE 8

## CBT - RADIADORES

		TIPO		NÚMERO ORIGINAL	PADRÃO		CONSTR.	
RP20004	TBE	1090 / 2100 / 8260 / 2500 / 2600 - Perkins		P-720.991.AS 03.005.102 / 06.005.102	Original	570	510	5TBE 8
RP20008	TBE	1105 / 2105 - MBB		P-720.991.05 04.005.102 / 07.105.010.02	Original	570	510	5TBE 8

## CAMECO - COLMÉIAS

		TIPO		PADRÃO		CONSTR.	CAB.
CP25021	TBG	Colhedeira Motor Caterpillar		Original	820	820	6 TBG 4
CP25026	TBC						6 TBC 5,5
CP25022	TBG	Colhedeira Motor MBB / Scania		Original	820	820	8 TBG 4
CP25024	TBC						8 TBC 5,5

## SLC JOHN DEERE - COLMÉIAS

		TIPO		PADRÃO		CONSTR.	CAB.
CP25011	TBE	5403 / 5605 / 5705		Original	460	522	4 TBE 8
CP25008	TBE						
CP25009	TBE	6405 6605 / 7500 / 7505		Original	540	498	4 TBE 8
CP25010	TBE						
CP25000	TBG	Colhedeira 2200		Original	720	595	6 TBG 4
CP25001	TBL						
CP25002	TBG	Colhedeira 6200 / 6300		Original	830	658	6 TBG 4
CP25003	TBL						
CP25004	TBG	Colhedeira 7200		Original	830	680	6 TBG 4
CP25005	TBL						
CP25007	TBG	Colhedeira 1165 / 1175 / 1185		Original	855	674	6 TBG 4
CP25006	TBL						





## CASE - COLMÉIAS

		TIPO		PADRÃO			CONSTR.	CAB.
CP20042 CP20051	TBE TBG	580 H		Especial Original	456	546	4 TBE 8 4 TBG 8	
CP20053	TBE	580 L		Especial	470	510	5 TBE 8	
CP20040	TBE	580 E		Original	475	405	3 TBE 8	
CP20043	TBE	W 7 E / W 18 / 20		Original	541	608	5 TBE 8	
CP20058	TBL	MX 135		Especial	572	563	6 TBL 8	Solda
CP20044	TBE	W 20 B		Original	580	640	5 TBE 8	
CP20054	TBL	621 C / 521 D		Especial	635	565	5 TBL 8	Solda
CP20048 CP20055	TBE TBL	W 20 B turbo		Opcional Super	684	640	5 TBE 8 5 TBL 8	
CP20050 CP20057	TBE TBL	W 20 D		Opcional Super	690	607	6 TBE 8 6 TBL 8	
CP20047 CP20052	TBE TBE	W 20 E		Opcional Reforçado	700	615	6 TBE 8 6 TBE 8	
CP20064 CP20059	TBE TBE	8920 / 8930 / 8940		Opcional Reforçado	715	723	6 TBE 8 6 TBE 8	Solda
CP20060 CP20063	TBE TBE	MX 270		Opcional Reforçado	725	520	6 TBE 8 6 TBE 8	Solda
CP20049 CP20056	TBE TBL	W 20 B - Turbo Moderno		Opcional Super	756	648	5 TBE 8 5 TBL 8	
CP20046	TBE	W 36		Original	813	737	4 TBE 8	
CP20061 CP20062	TBL TBL	A 7700 Colhedeira Cana A 7000 Colhedeira Cana - Modelo Antigo		Super Super	903 915	875 890	6 TBL 5,5 6 TBL 5,5	120 x 903 110 x 910

## CASE - RADIADORES

		TIPO		NÚMERO ORIGINAL	PADRÃO			CONSTR.
RP20051	TBG	580 H		E 64.147 / E 95.390	Original	456	546	4 TBG 8
RP20053	TBE	580 L		234.876 A1	Especial	470	510	5 TBE 8
RP20043	TBE	W 7 E		E 60.001	Original	541	608	5 TBE 8
RP20041	TBE	W 18 / 20		E 61.335	Original	541	608	5 TBE 8
RP20044	TBE	W 20 B		E 69.881 / E 96.526	Original	580	640	5 TBE 8
RP20064	TBE	8920 / 8930 / 8940		229.333 A1 / 229.332 A1 232.545 A1 / 131.752 A2 131.753 A2 / 140.501 A2	Original	715	723	6 TBE 8
RP20063	TBE	MX 270		87.410.434	Original	725	520	6 TBE 8
RP20056	TBL	W 20 B - Turbo Moderno		E 97.849	Super	756	648	5 TBL 8
RP20062	TBL	A 7700 - Colhedeira Cana		87.461.041	Super	915	890	6 TBL 5,5
RO20065	TCU	Rad. Óleo 580 L - c/ Rosca		ND	Original	445	480	
RO20053	TCU	Rad. Óleo 580 L - Engate		320.877 A1	Original	445	480	
RO20066	TCU	Rad. Óleo W 36 / W 20 / W 20 E		E 69.605	Original	687	305	
RO20062	TCU	Rad. Óleo A 7700		908.820	Original	726	760	



## CATERPILLAR - COLMÉIAS

		TIPO		NÚMERO ORIGINAL	PADRÃO		CONSTR.	CAB.
CP16085	TBC	D - 9	5H-8244 5H-8246	original	518 1008	6 TBC 5,5	CF	
CP16089	TBC	D - 9 B	1S-6162	original	587 1183	6 TBC 5,5	CF	
CP16087	TBC	D - 9	1M-7460	original	818 1075	6 TBC 5,5	CF	
CP16033	TBE	416 B	NA	Especial	560 565	4 TBE 8	Solda	
CP16034	TBE	416 C / D	NA	Especial	570 550	6 TBE 8	Solda	
CP16050	TBC	D - 2	5F-2141 8F-3135	Original	575 470	4 TBC 5,5	CF	
CP16109	TBC	933	3S-9304 8H-9577 5M-4027 3S-9307	Original	575 575	3 TBC 5,5	CF	
CP16110	TBC	955	8H-6245 8H-6246	Original	575 578	4 TBC 5,5	CF	
CP16100	TBC	D - 25	ND	Original	575 578	5 TBC 5,5	CF	
CP16051	TBC	D - 4	2H-1371 4F-7979 8F-0238 8F-0239	Original	595 478	3 TBC 5,5	CF	
CP16052	TBC	D - 4	7H-0677 7H-0678 7H-0679 9H-4771	Original	595 611	3 TBC 5,5	CF	
CP16053	TBC	D - 4	5S-8052	Original	660 705	3 TBC 5,5	CF	
CP16054	TBC		5S-4592	Original		4 TBC 5,5		
CP16055	TBC	D - 4	2P-4648 2Y-3084 2Y-4637	Original	710 705	3 TBC 5,5	CF	
CP16056	TBC		2P-4648 8N-3565	Original		4 TBC 5,5		
CP16057	TBC		2P-4335 2Y-3087 2Y-4640 7N-6223	Original		5 TBC 5,5		
CP16124	TBC	944	3K-3615 1M-4722	Original	610 640	5 TBC 5,5	CF	
CP16107	TBC	D - 315 / 8	4F-7976 8F-3136	Original	659 521	3 TBC 5,5	CF	
CP16061	TBC	D - 6	6H-9008 6H-9009 6H-9012 4H-2461	Original	679 611	4 TBC 5,5	CF	
CP16059	TBC		4F-7977	Original		5 TBC 5,5		
CP16065	TBC		4F-7977	Original		6 TBC 5,5		
CP16064	TBC	D - 6	2M-4798 5A-4391	Original	680 670	4 TBC 5,5	CF	
CP16066	TBC	D - 6	9M-8038 7S-2530 9M-1557 9M-6032	Original	762 897	4 TBC 5,5	CF	
CP16068	TBC	D - 6	7S-2385	Original	812 890	6 TBC 5,5	CF	
CP16069	TBC	D - 6	1P-3932 2Y-3083 4N-6298	Original	882 680	6 TBC 5,5	CF	
CP16070	TBC	D - 6	2P-3775 2Y-3085/6 7N-4367 7S-2384	Original	882 802	4 TBC 5,5	CF	
CP16071	TBC		1P-7752 7N-3542 7N-4384	Original		6 TBC 5,5		
CP16130	TBC		ND	Original		5 TBC 5,5		
CP16117	TBC	977	5H-8412 8H-4432	Original	685 590	5 TBC 5,5	CF	
CP16031	TBE	320 B	NA	Especial	700 730	5 TBE 8	Solda	
CP16032	TBE	320 C	NA	Especial	830 825	5 TBE 8	Solda	
CP16126	TBC	941 / 941 B / 951	5S-8036	Original	705 660	4 TBC 5,5	CF	
CP16127	TBC		8S-2640	Original		5 TBC 5,5		
CP16092	TBC	Moto - 12 / 120 - B Moto - 12 / 930	1M-7841 1M-7842 2M-0922 2Y-2967 7S-1086 8N-7859 9S-4997	Original	716 745	3 TBC 5,5	CF	
CP16091	TBC		2M-5493 2Y-3082 2Y-4312 4M-4420	Original		4 TBC 5,5		
CP16093	TBC		4M-4421 7S-1085	Especial		5 TBC 5,5		
CP16098	TBC	Moto - 12	6H-9001 6H-9002 6H-9005	Original	718 611	4 TBC 5,5	CF	
CP16097	TBC		4F-7974	Original		6 TBC 5,5		
CP16095	TBC	12	9B-2000	Original	725 734	5 TBC 5,5	CF	
CP16038	TBC	120 G	7N-7330 4Q-5026	Original	850 850	3 TBC 5,5	Solda	
CP16039	TBC			4 TBC 5,5				
CP16035	TBL	924 G	1.409.310	Super	750 820	5 TBL 8	Solda	
CP16036	TBL	924 F	1.104.347	Super	772 730	5 TBL 8	Solda	
CP16094	TBC	140	8S-7795	Original	755 835	3 TBC 5,5	CF	
CP16040	TBC	140 B	ND	Original	775 835	4 TBC 5,5	Solda	
CP16112	TBC	955 - H	3S-9738 4M-4775 7M-9660 9M-5551	Original	762 682	6 TBC 5,5	CF	
CP16108	TBC	D - 326 / 330 / 342	ND	Original	762 840	4 TBC 5,5	CF	
CP16122	TBC			5 TBC 5,5				



## CATERPILLAR - COLMÉIAS

		TIPO		NÚMERO ORIGINAL	PADRÃO		CONSTR.	CAB.
CP16114	TBC	966 - B		9M-8043 3S-4515	Original	764 787	6 TBC 5,5	CF
CP16073	TBC	D - 7		8B-9400 6B-8711 8B-9390	Original	771 927	4 TBC 8	Solda
CP16076	TBC	D - 7		5H-4111 5-H4220 5H-4184	Original	792 911	4 TBC 5,5	CF
CP16075	TBC	D - 7		4A-2580 2H-2123	Original	803 711	4 TBC 5,5	CF
CP16079	TBC	D - 7		ND	Original	935 990	6 TBC 5,5	CF
CP16078	TBC	D - 7		7M-2000	Original	935 1016	5 TBC 5,5	CF
CP16077	TBC			7M-2007 9M-7575	Original		6 TBC 5,5	
CP16074	TBC	D - 7		8F-3138 8F-3139 3B-2453	Original	1002 1000	4 TBC 5,5	CF
CP16215	TBC	D - 7		1S-8364 3S-3565 3S-4070 9S-9270 3R-2605 3S-4069	Original	1088 1015	6 TBC 5,5	CF
CP16224	TBC	D - 7 G		6N-1218	Original	1105 995	6 TBC 5,5	CF
CP16119	TBC	950		3S-2320	Original	775 610	6 TBC 5,5	CF
CP16101	TBC	DW - 15		8H-0890 4H-0890	Original	775 833	4 TBC 5,5	CF
CP16072	TBC	RD - 7		7B-4778 8B-9399	Original	787 843	4 TBC 5,5	CF
CP16106	TBC	DW - 21		2H-8657	Original	838 883	6 TBC 5,5	CF
CP16102	TBC	DW - 20		8F-20	Original	848 678	6 TBC 5,5	CF
CP16103	TBC	DW - 20		337	Original	850 700	6 TBC 5,5	CF
CP16080	TBC	D - 8		2A-1747 8F-2790	Original	851 1000	4 TBC 5,5	CF
CP16081	TBC	D - 8		1H-6786 4H-9776 6H-1545 6H-8727/8/9	Original	878 878	5 TBC 5,5	CF
CP16083	TBC	D - 8		6H-3446 7H-4089 8H-2943 7H-9651	Original	878 1011	4 TBC 5,5	CF
CP16082	TBC	D - 8		4H-9915 2M-751 8H-1729	Original	879 1003	6 TBC 5,5	CF
CP16084	TBC	D - 8 H		2M-8043 2M-8044 2M-8045 2M-8048 3S-6250 4M-5347 7M-4189 7M-5664 8S-2646 9M-3097	Original	954 1095	6 TBC 5,5	CF
CP16132	TBC	D - 8 H		2S-8728 8S-2645 8S-2639 5S-8440 4S-7813 5S-8439	Original	1155 1080	6 TBC 5,5	CF
CP16150	TBC	D - 8 K		6N-0957 8N-2602	Original	1155 1140	8 TBC 5,5	CF
CP16153	TBC	D - 8 L		7N-3112	Original	1207 1103	7 TBC 5,5	CF
CP16120	TBC	619 AC		2M-9055 4M-0133 7M-7116	Original	851 840	7 TBC 5,5	CF
CP16217	TBC	D - 5		5S-8451 5S-8450	Original	856 712	5 TBC 5,5	CF
CP16062	TBC			7N-4987	Original			
CP16041	TBC	140 G		2P-8613	Original	858 850	4 TBC 5,5	Solda
CP16104	TBC	DW - 20		1H-5775	Original	860 643	6 TBC 5,5	CF
CP16105	TBC	DW - 21		9H-9954	Original	874 946	5 TBC 5,5	CF
CP16111	TBC	955 - L		2P-1332	Original	910 580	7 TBC 5,5	CF
CP16136	TBC	955 - K		5S-5991	Original	968 705	6 TBC 5,5	CF
CP16123	TBC	627 MT		9S-3767	Original	955 962	6 TBC 5,5	CF
CP16115	TBC	966		1P-4404	Original	964 805	5 TBC 5,5	CF
CP16113	TBC	966 - C		5S-7647 9S-4104	Original		6 TBC 5,5	
CP16135	TBC	D - 398		6L-2344	Original	965 970	6 TBC 5,5	CF
CP16116	TBC	977		2M-5843 7M-4692 3S-9373	Original	970 840	6 TBC 5,5	CF
CP16042	TBC	977 L		1P-1683	Original	1027 645	8 TBC 5,5	CF
CP16128	TBC	621		5S-0602	Original	991 750	8 TBC 5,5	CF
CP16159	TBC	621		4N-4342 8N-5979	Original	1068 1027	7 TBC 5,5	CF
CP16045	TBC	631-C		4N-7271 7N-9314	Original	1225 1208	8 TBC 5,5	CF 48 Furos
CP16154	TBC	988-B		4N-9691 4N-9661	Original	1225 1208	8 TBC 5,5	CF 50 Furos
CP16133	TBC	992		7S-8845	Original	1320 1310	7 TBC 5,5	CF



## CATERPILLAR - RADIADORES

		TIPO		NÚMERO ORIGINAL	PADRÃO		CONSTR.
RP16034	TBE	416 D		ND	Especial	570 550	6 TBE 8
RP16035	TBL	924 G		1.409.310	Super	750 820	5 TBL 8
RP16036	TBL	924 F		1.104.347	Super	772 730	5 TBL 8

## CATERPILLAR - ELEMENTOS DE ÓLEO

		TIPO		PADRÃO		CONSTR.
E016035		924 G		Opcional	510 80	
E016036		924 F		Opcional	510 80	

## CLARK - COLMÉIAS

		TIPO		PADRÃO		CONSTR.
CP23164	TBE	Empilhadeira C - 300		Original	400 450	3 TBE 8
CP23166	TBG					4 TBE 8
CP23161	TBE	Empilhadeira GLY - 500		Especial	460 450	4 TBE 8

## CLARK - RADIADORES

		TIPO		NÚMERO ORIGINAL	PADRÃO		CONSTR.	
RP23166	TBG	Empilhadeira C - 300		3.307.723 / 3.311.484	Original	400 450	4 TBE 8	TODOS

## CUMMINS - COLMÉIAS

		TIPO		PADRÃO		CONSTR.	CAB.
CP12752	TBG	3.350.549		Especial	795 915	6 TBE 8	CF 23 x 3
CP12751							CF 15 x 3
CP12737	TBG	3.350.728		Especial	915 915	6 TBE 8	CF 23 x 3
CP12747							CF 20 x 3
CP12761							CF 15 x 3
CP12749	TBE	3.351.630		Original	1000 1000	6 TBE 8	CF 23 x 3
CP12750							CF 25 x 3

## DODGE - COLMÉIAS

		TIPO		PADRÃO		CONSTR.	CAB.
CP14003	TBE	D 100 / 400		Original	515 555	3 TBE 8	Lisa
CP14004	TBE	D 700 Gasolina / E 13 / E 21 Álcool		Original	555 635	3 TBE 8	Centro
CP14005	TBE	D 700 / 900 / 950 - Perkins		Opcional	555 635	3 TBE 8	Deslocada
CP14000	TBE						
CP14007	TBE						
CP14008	TBE	D 950 S - MWM		Original	725 625	3 TBE 11	
CP14021	TBE						



## FIAT - COLMÉIAS

		TIPO		PADRÃO		CONSTR.	CAB.	
CP13010	TBE	120 / 130 / 140		Original	525	640	5 TBE 8	
CP13003	TBE	180 / 210 CM		Original	610	600	6 TBE 8	
CP13001	TBE	FNM 9500 / D 11000		Especial	620	630	5 TBE 8	
CP13018	TBE	210 S		Original	660	600	6 TBE 8	
CP13012	TBE	190 H - F		Original	760	600	6 TBE 8	
CP13013	TBE	190 H - F / 190-30 - Turbo		Especial	760	600	7 TBE 8	
CP13020	CTM	Ducato 2.5 / 2.8 D / TD		Especial	790	410	2 CTM 14	Solda Grampo
CP13021	CTM	Ducato 2.5 D / TD AC		Original	790	410	2 CTM 14	Solda Grampo
CP13017	CTM	Ducato 2.5 D / TD AC		Especial	1000	410	2 CTM 14	Solda Grampo
CP13016	CTM	Ducato 2.5 D / TD AC		Original	1000	410	2 CTM 14	Solda Grampo

## FIAT - RADIADORES

		TIPO		NÚMERO ORIGINAL	PADRÃO		CONSTR.		
RP13020	CTM	Ducato 2.5 / 2.8 TD		1.331.792.080 / 1.307.395.080	Especial	790	410	2 CTM 14	94 >
RP13017	CTM	Ducato 2.5D / TD AC		1.311.521.080	Especial	1000	410	2 CTM 14	> 01

## FIAT ALLIS - COLMÉIAS





		TIPO		NÚMERO ORIGINAL	PADRÃO		CONSTR.	CAB.	
CP21002	TBE	AD 7 B / S 90		NA	Original	555	635	5 TBE 5,5	
CP21009	TBE	AD 7 B / S 90		NA	Reforçado	555	635	5 TBE 5,5	
CP21223	TBG	70 CI		569.078 / 4.694.602	Original	586	595	5 TBG 8	C/F
CP21222	TBG	70 CI		569.078 / 4.694.602	Reforçado	586	595	5 TBG 8	C/F
CP21110	TBE	AD 7 - C / AD-7 G		NA	Original	590	540	5 TBE 8	
CP21221	TBG	60 CI		NA	Reforçado	607	590	5 TBG 8	C/F
CP21000	TBE	134 A / 1500 B / 1900 B / FG 70		NA	Original	660	598	5 TBE 8	
CP21006	TBG	FG 70 / FR 10		NA	Opcional	729	658	5 TBG 8	
CP21007	TBG	FG 70 / FR 10		NA	Reforçado	729	658	5 TBG 8	
CP21010	TBG	FD 9		NA	Opcional	733	658	6 TBG 8	
CP21008	TBG	FD 9		NA	Reforçado	733	658	6 TBG 8	
CP21011	TBE	AD 14 - Motor Fiat		NA	Opcional	770	750	6 TBE 8	
CP21003	TBE	AD 14 - Motor Fiat		NA	Reforçado	770	750	6 TBE 8	
CP21004	TBE	AD 14 - Motor Scania		NA	Original	790	770	4 TBE 8	
CP21001	TBL	AD 14 - Motor Scania		NA	Opcional	850	770	6 TBL 5,5	
CP21005	TBL	AD 14 - Motor Scania		NA	Super	850	770	6 TBL 5,5	

## FIAT ALLIS - RADIADORES

		TIPO		NÚMERO ORIGINAL	PADRÃO		CONSTR.		
RP21009	TBE	AD 7 B / S 90		8.320.681 / 8.320.487 4.962.003 / 8.320.165	Reforçado	555	635	5 TBE 5,5	Todos
RO21013	TCU	Radiador Óleo S 90 (Mangueira)		8.321.311	Original	370	386		Todos
RO21015	TCU	Radiador Óleo S 90 (Rosca)		ND	Original	370	400		Todos
RO21014	TCU	Radiador Óleo FE 105		75.219.598	Original	535	390		Todos









## FORD - COLMÉIAS

		TIPO	  	PADRÃO	 A x L	CONSTR.	CAB.		
CP11099	TBE	Jeep 51 - Militar		Original	350	500	3 TBE 8		Todos
CP11011 CP11010	TBE	F 100 4 cil / Maverick 4 cil.		Original	362	514	2 TBE 8 3 TBE 8	Lisa	Todos
CP11003 CP11002	TBE TBG	Rural 4 / 6 cil.		Especial Original	370	470	4 TBE 8 4 TBG 8		60 / 85
CP11013 CP11012	TBE	Maverick 6 / 8 cil.		Original	413	514	2 TBE 8 3 TBE 8	Lisa	75 / 81
CP11001 CP11019	TBE TBG	Jeep Willys 4 / 6 cil.		Especial Original	420	420	4 TBE 8 4 TBG 8		55 / 85
CP11009	TBE	Landau		Especial	442	605	3 TBE 8	Lisa	67 / 84
CP11007 CP11008	TBE	Galaxie		Original	445	514	2 TBE 8 3 TBE 8	Lisa	67 / 83
CP14069 CP14070 CP14071 CP14072	CTY CTM TBE TBE	Cargo 8 ton.		Original Especial Opcional Super	465	615	2 CTY 16 3 CTM 14 3 TBE 8 4 TBE 8	65 x 626	97 / 99
CP14046 CP14048 CP14006 CP14009	CTY CTM TBE TBE	Cargo 8 ton.		Original Especial Opcional Super	465	623	2 CTY 16 3 CTM 14 3 TBE 8 4 TBE 8	65 x 640	97 / 99
CP11029 CP11030 CP11025	CTM TBE TBE	F-1000 Delta - Intercooler		Original Especial Especial	476	464	3 CTM 14 3 TBE 11 3 TBE 11	Solda 66 Solda 66 Grampo	95 / 98
CP14047 CP14057 CP14040 CP14041	CTY CTM TBE TBE	Cargo 815		Original Especial Opcional Super	500	623	2 CTY 16 3 CTM 14 3 TBE 8 4 TBE 8	65 x 640	00 >
CP11004	TBE	Corcel / Pampa / Del Rey		Original	505	330	2 TBE 8		69 / 83
CP11015 CP11050 CP11016	TBE TBG TBE	F 1000 / 2000 / 4000 - MWM		Original Especial Super	506	666	2 TBE 8 3 TBG 8 3 TBE 8	MC	72 / 91
CP11017	TBE	F 4000 - Motor Ford		Original	506	666	3 TBE 8	MC	Todos
CP11026 CP11027	TBE TBE	F 600 - Gasolina F 600 - Diesel		Original Original	515	570	3 TBE 8 4 TBE 8	Lisa	55 / 71 55 / 68
CP11018 CP11023	TBE TBE	F-7000 MWM / F 600 - Gasolina F 600 - Gasolina Adaptado MBB		Original Especial	556	666	3 TBE 8 4 TBE 8	MC	72 / 88 72 >
CP11020 CP11053	TBE TBG	F 600 / 750 Avarentão - F 11000 > 21000 - MWM		Original Opcional	600	666	4 TBE 8 4 TBG 8	MC	> 91
CP11024	CTM	Cargo 1113 / 1313 / 1215 / 1415 / 1419 - MWM		Especial	610	634	3 CTM 14	90 x 655	85 >
CP11046 CP11067 CP11072 CP11055	CTM CTM TBE TBE	Ônibus Urbano 1618		Original Especial Opcional Super	640	623	2 CTM 14 3 CTM 14 3 TBE 8 4 TBE 8	72 x 640	96 >
CP11069 CP11066 CP11042 CP11041	CTM CTM TBE TBE	Cargo 1114 / 1117 / 1314 / 1317 / 1514 / 1516 / 1517 / 1618 / 2216 / Ônibus Urbano 1618		Opcional Original Econômica Especial	640	634	2 CTM 14 3 CTM 14 3 TBE 8 4 TBE 8	90 x 655	85 >
CP11047 CP11032 CP11048	CTM CTM CTM	F 250 / 350 / 4000		Especial Especial Especial	670	774	2 CTM 14	Solda Grampo 75 x 778 Grampo 75 x 772	99 >
CP11057 CP11058 CP11056	CTM TBE TBE	F 1000 / 4000 - Diesel		Original Opcional Especial	700	464	3 CTM 14 3 TBE 8 3 TBE 8	Solda 66 Solda 66 Grampo	95 / 98
CP11036 CP11037	TBE TBE	F 1000 / 4000 - Gasolina / Álcool F 1000 / 4000 - Diesel Turbo		Original Original	700	469	2 TBE 8 3 TBE 8	Solda 73 desl. C/ dente	92 / 94
CP11039	TBE	F 1000 / 4000 - Diesel Turbo - Argentina		Original	700	490	3 TBE 8	Solda 72	92 / 94



## FORD - COLMÉIAS

		TIPO	  	PADRÃO	 A x L	CONSTR.		CAB.
CP11045 CP11065 CP11044 CP11043	CTM CTM TBE TBE	F 12000 / 14000		Original Especial Opcional Super	706 623	2 CTM 14 3 CTM 14 3 TBE 8 4 TBE 8	96 / 00	72 x 640
CP11054 CP11051	CTM CTM	Cargo 1617 / 1622 / 2322 / 2422 - Intercooler		Original Especial	706 634	2 CTM 14 3 CTM 14	91 / 93	105 x 655
CP11061 CP11064 CP11031 CP11080	CTM CTM TBE TBE	Cargo 1519 / 1521 / 1621 / 2319 / 2321 / 1623 / 2323 / 2422 / 3223 / 3224 / 3021 - Intercooler		Original Especial Canavieiro Betoneira	706 634	2 CTM 14 3 CTM 14 4 TBE 8 4 TBE 8	91 / 93	90 x 655
CP11081	CTM	F-14000 - Pitbull		Especial	715 703	3 CTM 14	Todos	Solda
CP11077 CP11063 CP11059 CP11084	CTM CTM TBE TBE	Cargo 1622 / 2630/ 4030 - Intercooler		Original Especial Canavieiro Betoneira	746 623	2 CTM 14 3 CTM 14 4 TBE 8 4 TBE 8	99 / 00	72 x 640
CP11079 CP11062 CP11085 CP11073	CTM CTM TBE TBE	Cargo 1622 / 2630/ 4030 - Intercooler		Original Especial Super Betoneira	746 634	2 CTM 14 3 CTM 14 4 TBE 8 4 TBE 8	99 / 00	90 x 655
CP11052 CP11049	TBE TBE	Cargo 1622 / 2422 / 2425		Betoneira Betoneira	756 756 623 634	4 TBE 8 4 TBE 8	02 > 02 >	72 x 640 90 x 655
CP11092 CP11071 CP11035 CP11034	CTY CTM TBE TBE	Cargo 1731 / 2425 / 2625 / 2630 / 2631 / 4030 / 4031		Original Especial Canavieiro Betoneira	806 623	2 CTY 16 3 CTM 14 4 TBE 8 4 TBE 8	03 >	72 x 640
CP11033 CP11040 CP11060 CP11089	CTY CTM TBE TBE	Cargo 1731 / 2425 / 2625 / 2630 / 2631 / 4030 / 4031		Original Especial Canavieiro Betoneira	806 634	2 CTY 16 3 CTM 14 4 TBE 8 4 TBE 8	03 >	90 x 655
CP11038	CTM	Cargo Eletrônico		Original	806 623	3 CTM 14	06 >	82 x 645
CP11087	CTM	Cargo 1722 / 2422 / 2622 / 4331 - Eletrônico		Original	840 615	3 CTM 14	07 >	82 x 645
CP11093 CP11070 CP11091 CP11086	CTY CTM TBE TBE	Cargo 4030 / 4031 / 4331		Original Especial Canavieiro Betoneira	866 623	2 CTY 16 3 CTM 14 4 TBE 8 4 TBE 8	03 >	72 x 640
CP11094	CTM	Cargo Eletrônico		Original	866 623	3 CTM 14	06 >	82 x 645
CP11095 CP11096 CP11097 CP11098	CTY CTM TBE TBE	Cargo 4030 / 4031 / 4331		Original Especial Canavieiro Betoneira	866 634	2 CTY 16 3 CTM 14 4 TBE 8 4 TBE 8	03 >	90 x 655



## FORD - RADIADORES

		TIPO		NÚMERO ORIGINAL	PADRÃO		CONSTR.	
RP14019 RP14020	TBE	Cargo Aquecimento - Mangueiras Retas Cargo Aquecimento - Mangueiras Curvas		ND ND	Especial	195 120	2 TBE 11	> 02 03 >
RP11000 RP11002	TBG TBG	Rural / Pick up 4 cil. / F 75 Rural / Pick up 6 cil.		BD9B.8005-E 15.320	Original Original	370 470	3 TBG 8 4 TBG 8	75 / 83 60 / 76
RP11005 RP11019	TBG TBG	Jeep Willys 4 cil. Jeep Willys 6 cil.		BD9B.8005-C 11.000	Original Original	420 420	3 TBG 8 4 TBG 8	76 / 83 55 / 76
RP11090	CTY	Cargo 8 ton.		2UH.121.253	Especial	465 623	2 CTY 16	> 00
RP11029	CTM	F-1000 - Interculada		96TU.8005-BA 2SC.121.253-C	Original	476 464	3 CTM 14	95 / 98
RP11083	CTY	Cargo 815		YC45.8005-AA / AB	Especial	500 623	2 CTY 16	01 >
RP11015 RP11016	TBE TBE	F 1000 / 2000 / 4000 - MWM F 1000 / 2000 / 4000 - MWM		BE0C.8005-A 91TU.8005-AA	Especial Super	506 666	2 TBE 8 3 TBE 8	72 / 91 73 / 91
RP11021 RP11020	TBE TBE	F 19000 / 21000 - MWM F 600 Avarentao / F 11000 > 21000 - Perkins		BE3T.8005-C BD9T.8005-D	Original Original	600 666	4 TBE 8	77 / 92 > 91
RP11028	CTM	F 12000 / 14000 - Sapão		T75.121.253-A	Especial	640 623	3 CTM 14	92 / 95
RP11046 RP11069	CTM CTM	B 1618 / B 1621 - Ônibus Urbano B 1618 - Ônibus Urbano		2RP.121.253-B TAR.121.253	Original Original	640 623 640 634	2 CTM 14 2 CTM 14	95 / 96 93 / 94
RP11088	CTM	Cargo 1114 / 1215 / 1415		TEG.121.253	Original	640 634	3 CTM 14	91 >
RP11047	CTM	F-4000 - MWM F-250 F-350		XCH.8005-AA 1C35.8005-AA F81H.8008-GA	Especial Especial Especial	670 774	2 CTM 14	99 >
RP11057	CTM	F-1000		2SB.121.253-H / K	Original	700 464	3 CTM 14	96 / 98
RP11022	CTM	F-4000 - Cummins		96TU.8005-CA 2SK.121.253	Original	700 464	3 CTM 14	96 / 98
RP11045	CTM	F 12000 / 14000 - Sapão Moderno		2SL.121.253-K	Original	706 623	2 CTM 14	96 >
RP11061	CTM	Cargo 1422 / 1215 / 1415 Cargo 1519 / 1521 / 1621 / 2319 / 2321 / 3021 Cargo 1617 Cargo 1617 / 1721 Cargo 1622 / 2322 / 2422 - Intercooler Cargo 1622 / 2322 / 2422 - Intercooler Cargo 1623 / 2323 / 3223 / 3224 - Intercooler Cargo 3530 - Intercooler		2RK.121.253-A / XC.8005-BA 2RN.121.253 TJG.121.253 2SU.121.253-A / XC.8005-FA TMJ.121.253 98HU.8005-HA 87HU.8005-HA TRG.121.253	Especial	706 623	2 CTM 14	91 >
RP14037	CTM	Cargo 1422		2RN.121.253-A 98HU.8005-JA	Especial	706 634	2 CTM 14	92 >
RP11081	CTM	F-14000 - Pitbull		XC3Z.8005-DA	Especial	715 703	3 CTM 14	00 >
RP11100	CTM	Cargo 2630 / 3530 / 4030 - Intercooler Cargo 1622 / 2422 / 2425		2RT.121.253-A / 98HU.8005-LA 2UC.121.253 98HU.8005-BA / XC45.8005-DA	Especial	746 623	2 CTM 14	94 >
RP11077	CTM	Cargo 2622 / 1722 / 2422 - Euro II		2C458005-GA / GB	Original	746 623	2 CTM 14	02 >
RP11092 RP11082	CTY CTY	Cargo 1731 / 2425 / 2625 / 2630 / 2631 / 4031 Cargo 2425		2C45.8005-EB / EA XC45.8005-KA	Especial Especial	806 623	2 CTY 16	01 > 01 >
RP11087	CTM	Cargo 1722 / 2422 / 2622 / 4331		6C458005-BB	Original	840 615	3 CTM 14	08 >
RP11093	CTY	Cargo 4031 / 4331		2C45.8005-AA / AB	Especial	866 623	2 CTY 16	03 >

## FORD - INTERCOOLERS

		TIPO		NÚMERO ORIGINAL		CONSTR.	
IP11670	AL	F1000 - Delta		96TU.6K775-BA	320 215	3 AL 8	95 / 98
IP14953	AL	CARGO - Leve		XC45.6K775-AA / 2RE.117.249	578 368	3 AL 8	96 >
IP14824	AL	CARGO - Pesado		XC45.6K775-BA / 96HU.6K775-AA / TRG.117.249 / 2RT.117.249	588 627	3 AL 8	91 >





## FORD NEW HOLLAND - COLMÉIAS

		TIPO		PADRÃO			CONSTR.	CAB.
CP21354	TBG	5030		Original	390	450	5 TBG 8	
CP21342	TBE	4600 / 4610 / 4810		Original	405	445	3 TBE 8	
CP21355	TBL	5630 / 7630		Original	422	446	5 TBL 8	
CP21341	TBE	4500 / 5600 / 5610 / 6600 - Retroescavadeira		Original	450	445	3 TBE 8	
CP21351	TBE		4 TBE 8					
CP21343	TBE	4500 / 5600 / 5610 / 6600 - Trator		Original	450	445	4 TBE 8	
CP21345	TBE	6510 / 6610 / 7600 / 7610		Original	455	460	4 TBE 8	
CP21358	TBL	TL 70 / 75 / 80 / 100		Especial	460	522	4 TBL 8	Solda Grampo Solda
CP21361	TBL		5 TBL 8					
CP21357	TBL		5 TBL 8					
CP21363	TBE	TS - Cabinado / Plataforma		Original	508	483	5 TBE 8	Grampo Solda
CP21359	TBE							
CP21352	TBL	7830		Original	544	446	5 TBL 8	
CP21346	TBE	7810 - Turbinado		Original	572	450	5 TBE 8	
CP21364	TBE	TM 120 / 135 / 140 / 150 / 165		Original	633	502	5 TBE 8	Grampo Solda
CP21360	TBE							
CP21350	TBG	8830		Original	670	552	6 TBG 8	
CP21365	TBE	MU7 / MX 270		Original	725	502	5 TBE 8	Grampo Solda
CP21356	TBE							

## FORD NEW HOLLAND - RADIADORES

		TIPO		NÚMERO ORIGINAL	PADRÃO			CONSTR.
RP21354	TBG	5030		84.995.078N	Original	390	450	5 TBG 8
RP21357	TBL	TL 70 / 75 / 80 / 100		73.400.396 / 82.992.180 / 82.992.179	Original	460	522	5 TBL 8
RP21352	TBL	7830		9.575.706	Original	544	446	5 TBL 8
RP21360	TBE	TM 120 / 135		73.400.502	Original	633	502	5 TBE 8
RP21362	TBE	TM 140 / 150 / 165		73.400.504 / 82.013.306-B	Original			
RP21350	TBG	8830		9.575.846	Original	670	552	6 TBG 8
RO21360	TCU	Radiador Óleo TM 180		82.000.903	Original	485	250	

## FORD NEW HOLLAND (COLHEDEIRAS) - COLMÉIAS

		TIPO		PADRÃO			CONSTR.	CAB.
CP21480	TBG	Colhedeira Clayson 4040 / 5050 / 1530		Original	600	635	6 TBG 4	130 x 640
CP21481	TBL		6 TBL 4					
CP21484	TBG	Colhedeira Clayson 8040 / 8055		Original	660	790	6 TBG 4	130 x 800
CP21485	TBL		6 TBL 4					
CP21482	TBG	Colhedeira Clayson 8040 / 8055		Original	670	770	6 TBG 4	130 X 780
CP21483	TBL		6 TBL 4					
CP21486	TBG	Colhedeira TC 55 / 57		Original	733	770	6 TBG 4	120 x 780
CP21487	TBG	Colhedeira TC 59		Original	820	770	7 TBG 4	120 x 780
CP21348	TBL	Colhedeira CNH		Original	920	894	6 TBL 4	115 x 900



## GM- COLMÉIAS

		TIPO		PADRÃO		CONSTR.	CAB.	
CP12002 CP12004	TBE TBE	Opala / Caravan / AC 10 4 cil.		Original Especial	320 470	2 TBE 8 3 TBE 8		69 / 82
CP12000 CP12001	TBE TBE	Chevette		Original Especial	328 380	2 TBE 8 3 TBE 8		Todos
CP12007	TBE	Opala 6 cil		Original	360 580	2 TBE 8		> 74
CP12012	TBE	C 60 - Gasolina		Original	505 585	3 TBE 8		55 / 81
CP12015 CP12036 CP12017	TBE TBG TBE	C 10 / D 10 / Veraneio 6 cil.		Original Especial Super	515 585	2 TBE 8 3 TBG 8 3 TBE 8		67 / 84
CP12013 CP12038	TBE TBG	D 60 - Diesel		Original Econômico	515 585	4 TBE 8 4 TBG 8		55 / 80
CP12021 CP12039	TBE TBG	D 70 / 80 - Diesel		Original Econômico	517 632	4 TBE 8 4 TBG 8		81 / 84
CP12019	TBE	Detroit		Original	530 640	4 TBE 8	Lisa	76 / 79
CP12031 CP12026	CTM TBE	Opala 6 cil. # AC		Original Opcional	565 425	2 CTM 14 2 TBE 11		80 / 84
CP12003 CP12011	CTM TBE	Opala 6 cil. # AC		Original Opcional	588 430	2 CTM 14 2 TBE 11		85 / 92
CP12032 CP12025	CTM TBE	Opala 6 cil. # AC		Original Opcional	602 377	2 CTM 14 2 TBE 11		75 / 79
CP24550 CP24553	CTY TBE	Space Van / Traffic - Gasolina / Diesel		Original Opcional	630 330	2 CTY 16 2 TBE 11		89 >
CP12030 CP12028	CTM TBE	D 20 / 40 / C 20 / 40		Original Opcional	659 468	3 CTM 14 3 TBE 8		90 >
CP12024	TBE	D 20 / 40 / C 20 / 40 - Versão Pinguim		Especial	659 490	3 TBE 11		85 >
CP12029 CP12022	CTM TBE	D 11000 > 22000 / AC 60 > 90		Original Opcional	720 590	3 CTM 14 3 TBE 8		90 >
CP12023	TBE	D 11000 > 22000 / AC 60 > 90 - Versão Pinguim		Especial	720 620	3 TBE 11		85 >

## GM - RADIADORES

		TIPO		NÚMERO ORIGINAL	PADRÃO		CONSTR.	
RP12015 RP12017	TBE TBE	C 10 / Veraneio		7.321.340	Original Especial	515 585	2 TBE 8 3 TBE 8	> 84
RP12016 RP12018	TBE TBE	D 10		94.602.284	Original Especial	515 585	2 TBE 8 3 TBE 8	> 84
RP12013	TBE	D 60		7.316.899 / 93.277.987	Original	515 585	4 TBE 8	> 80
RP12021	TBE	D 70 / 80		94.616.030	Original	517 632	4 TBE 8	81 / 84
RP24550 RP24552	CTY CTY	Space Van - Gasolina Space Van - Diesel		7.702.093.794 7.702.094.077	Original Original	630 330	2 CTY 16	89 / 97
RP12028 RP12020 RP12024	TBE TBE TBE	A/C - 20 D 20 / 40 D 20 / 40		94.653.941 52.256.911 / 52.252.230 94.629.766	Especial Especial Especial	659 490	3 TBE 11	85 / 94 88 > 85 / 87
RP12033 RP12023 RP12034	TBE TBE TBE	D 60 / 70 / 80 / 90 > D 11000 AC 60 / 70 / 80 / 90 D 60 / 70 / 80 / 90 > D 11000		94.629.746 94.629.747 52.297.549	Especial Especial Especial	720 620	3 TBE 11	85 / 87 85 > 88 >



## HYSTER - COLMÉIAS

		TIPO		PADRÃO			CONSTR.
CP23001 CP23000	TBG TBE	804.538		Original Especial	384	498	4 TBG 8 4 TBE 8
CP23003 CP23006	TBG TBE	H 40 / 50 / 60 / J		Original Especial	438	498	4 TBG 8 4 TBE 8
CP23016 CP23012	TBG TBE	H-50 J		Original Especial	440	585	4 TBG 8 4 TBE 8
CP23014	TBE	H 45		Original	483	440	5 TBE 8
CP23015	TBL	HXM 55		Original	486	438	4 TBL 8
CP23004 CP23002	TBG TBE	H 35 / 45 / 55 / 60 N		Original Especial	492	498	4 TBG 8 4 TBE 8

## HYSTER - RADIADORES

		TIPO		NÚMERO ORIGINAL	PADRÃO			CONSTR.
RP23001	TBG	H 40 / 50 / 60 K - s/ Deflector		804.538	Original	384	498	4 TBG 8
RP23003	TBG	H 40 / 50 / 60 / K - s/ Deflector		803.191	Original	438	498	4 TBG 8
RP23002	TBG	H 40 / 50 / 60 / K - s/ Deflector		804.323	Original	438	498	4 TBG 8
RP23004	TBG	H 35 / 45 / 55 / 60 N - s/ Deflector		803.048	Original	492	498	4 TBG 8

## HYUNDAI - COLMÉIAS

		TIPO		PADRÃO			CONSTR.	CAB.
CP24651 CP24654 CP24652	TBE TBE TBE	H 100		Opcional Original Especial	400	595	2 TBE 11 3 TBE 8 3 TBE 11	Solda Solda Solda

## HYUNDAI - RADIADORES

		TIPO		NÚMERO ORIGINAL	PADRÃO			CONSTR.
RP24654 RP24652	TBE TBE	H 100		25.343.600	Especial Super	400	595	3 TBE 8 3 TBE 11

## IDEAL - COLMÉIAS

		TIPO		PADRÃO			CONSTR.	CAB.
CP12400 CP12401	TBG TBL	1175		Original Especial	580	630	6 TBG 4 6 TBL 4	115 x 635
CP12402 CP12403	TBG TBL	1175 DS		Original Especial	605	630	6 TBG 4 6 TBL 4	115 x 635
CP12404 CP12405	TBG TBL	1175 / 9075		Original Especial	630	630	6 TBG 4 6 TBL 4	130 x 635



## IVECO - COLMÉIAS

		TIPO		PADRÃO		CONSTR.	CAB.	
CP13206	CTY	Eurocargo		Especial	570	606	2 CTY 16	Solda
CP13202	CTY	Daily		Original	625	380	2 CTY 16	Solda
CP13203	CTY	Daily turbo		Original	625	445	2 CTY 16	Solda
CP13209	CTY	Daily Turbo - Moderna		Especial	650	445	2 CTY 16	Solda
CP13204	CTM	Eurotech		Especial	800	748	3 CTM 14	Solda 70 x 770
CP13200	CTY			Original			2 CTY 16	
CP13205	CTM	Eurotech		Especial	800	783	3 CTM 14	Solda 70 x 784
CP13212	CTM	Stralis		Especial	900	748	3 CTM 14	Solda 70 x 770
CP13214	CTY			Original			2 CTY 16	

## IVECO - RADIADORES

		TIPO		NÚMERO ORIGINAL	PADRÃO		CONSTR.	
RP13200	CTY	Eurotech		41.008.464	Original	795	748	2 CTY 16

## KIA- COLMÉIAS

		TIPO		PADRÃO		CONSTR.	CAB.		
CP24450	TBE	Besta 2.2		Opcional	348	560	3 TBE 8	Solda 64	Todos
CP24452	TBE		Original	3 TBE 11					
CP24455	TBE	Besta 2.7		Original	375	560	3 TBE 11	Solda 55	> 99
CP24453	TBE		Opcional	3 TBE 8					
CP24454	TBE	Besta GS 2.7 / GS 3.0		Original	375	560	3 TBE 11	Solda 64	00 >
CP24451	TBE		Opcional	3 TBE 8					
CP24458	TBE	Bongo K2700 / K3000		Original	400	560	3 TBE 11	Solda 64	Todos
CP24431	TBE		Opcional	3 TBE 8					
CP24461	CTM	Sportage		Original	455	525	2 CTM 14	Solda 46 x 530	

## KIA - RADIADORES

		TIPO		NÚMERO ORIGINAL	PADRÃO		CONSTR.		
RP24452	TBE	Besta 2.2		NK74.015.200B	Original	348	560	3 TBE 11	Todos
RP24450	TBE		Opcional						
RP24453	TBE	Besta 2.7		OK72.415.200	Opcional	375	560	3 TBE 8	> 98
RP24454	TBE	Besta Grand 3.0 - GS 2.7		OK77B152.00A / B	Original	375	560	3 TBE 11	01 >
RP24451	TBE		Opcional						
RP24456	TBE	Besta GS 2.7		OK72A15.200	Original	375	560	3 TBE 11	> 99
RP24457	TBE		Opcional						
RP24430	TBE	Bongo K2400		OK65E15.200C	Original	375	560	3 TBE 11	Todos
RP24431	TBE	Bongo K2700		OK60A15.200B	Opcional	400	560	3 TBE 8	> 99
RP24460	TBE		Original						
RP24432	TBE	Bongo K3000 - K2700		OK622.152B	Opcional	400	560	3 TBE 8	00 >
RP24458	TBE		Original						



## KOMATSU - COLMÉIAS

		TIPO		NÚMERO ORIGINAL	PADRÃO			CONSTR.	CAB.
CP20361	TBG	D-30 E - Reforçada	112003B1460	Opcional	595	615	6 TBG 8	CF	
CP20360	TBG	D-50 A - Reforçada	1310341680	Opcional	595	630	6 TBG 8	CF	
CP20363	TBL	D-41 E	DDK04143A	Super	678	620	5 TBL 8	Solda	
CP20366	TBL	WA-180	4170311600 / 41703B1200	Super	750	612	5TBL 5,5	Solda	
CP20362	TBG	D-65 A / E - Reforçada	14403B2460 / 1430311210	Opcional	803	690	6 TBG 8	CF	
CP20367	TBG		1440311181	Florestal			6 TBG 4		
CP20364	TBG	D-65 E / D-68 - Reforçada	14403B5480	Opcional	825	840	6 TBG 8	CF	
CP20371	TBE	D-61	ND	Especial	864	470	7 TBE 8	Solda	

## KOMATSU / HUBER WARCO - COLMÉIAS

		TIPO		PADRÃO			CONSTR.
CP20372	TBE	Motoniveladora - MB	Original	725	640	5 TBE 8	
CP20373	TBE	Motoniveladora - Scania	Original	743	707	4 TBE 8	
CP20379	TBE	Motoniveladora - Cummins	Original	746	700	5 TBE 8	
CP15008	TBE	Motoniveladora - Scania	Original	790	774	4 TBE 8	

## KOMATSU / HUBER WARCO - RADIADORES

		TIPO		NÚMERO ORIGINAL	PADRÃO			CONSTR.
RP20372	TBE	Motoniveladora 11 DM - MB	6.300.428	Original	725	640	5 TBE 8	
RP20374	TBE	Motoniveladora 165 S - Scania	530.473 / 6.104.493	Original	790	774	4 TBE 8	
RP20371	TBE	D-61	ND	Especial	864	470	7 TBE 8	
RO20370	TCU	Radiador Óleo PC 150 SERIE 3 - c/ Tanque	21K0339470	Original	640	594		
RO20369	TCU	Radiador Óleo PC 150 SERIE 5 - c/ Cotovelos	ND	Original	640	603		
RO20376	TCU	Radiador Óleo PC 200	ND	Original	880	735		

## MWM - COLMÉIAS

		TIPO		PADRÃO			CONSTR.
CP 21702	TBE	D 225-3 / 4 / D 229-3 / 4	Original	440	530	3 TBE 8	
CP 21701	TBE	D 225-6	Original	520	530	5 TBE 8	
CP 21700	TBE	D 229-6 Turbinado	Original	660	530	5 TBE 8	
CP 21706	TBE	6.10 TCA	Original	808	773	4 TBE 8	

## MWM - RADIADORES

		TIPO		NÚMERO ORIGINAL	PADRÃO			CONSTR.
RP 21702	TBE	D 225-3 / 4 / D-229-3 / 4 - c/Deflector	9.225.0.052.003.7	Original	440	530	3 TBE 8	
RP 21701	TBE	D 225-6 / D 229-6 - c/Deflector	9.225.0.052.001.7	Original	520	530	5 TBE 8	
RP 21700	TBE	D 229-6 turbinado - c/Deflector	9.229.0.052.001.7	Original	660	530	5 TBE 8	
RP 21706	TBE	6.10 TCA - s/Deflector	9.610.0.052.002.6	Original	808	773	4 TBE 8	



## MWM - INTERCOOLERS

	TIPO		PADRÃO		CONSTR.	
IP21707	AL	6.10 TCA	Original	757 730	3 AL 8	Todos

## MF (AGCO) - COLMÉIAS

	TIPO		PADRÃO		CONSTR.	CAB.		
CP22023	TBG	250 X	Original	350 397	4 TBG 8		Todos	
CP22018	TBE	451	Original	430 390	5 TBE 8		Todos	
CP22000	TBE	50 / 65 X / 65 R / 85	Original	440 400	3 TBE 8	Abaulada	Todos	
CP22021	TBE	250 S / 265 - Advanced	Original	450 496	4 TBE 8		03 / 06	
CP22010	TBE	265 / 275 / 471 - Advanced	Original	460 483	4 TBE 8	Grampo Solda	07 >	
CP22019	TBE	265 / 275 / 471 - Advanced	Especial		4 TBE 8		Grampo Solda	07 >
CP22012	TBE	275 / 283 / 290	Original		5 TBE 8		Grampo Solda	> 06
CP22020	TBE	275 / 283 / 290	Especial		5 TBE 8		Solda	> 06
CP22008	TBL	299	Original	476 510	6 TBL 8			
CP22015	TBE	620	Original	480 495	5 TBE 8			
CP22007	TBE	292 / 295 / 296 / 297	Original	487 502	5 TBE 8			
CP22001	TBE	85 X / 235 / 250	Original	488 400	3 TBE 8	Abaulada		
CP22002	TBE		Especial		4 TBE 8			
CP22003	TBE	265 / 270 / 275 / 285 / 290	Original	488 400	3 TBE 8	Quadrada		
CP22016	TBL		Especial		4 TBL 8			
CP22004	TBE		Especial		4 TBE 8			
CP22005	TBE	95 X / I	Original	540 400	5 TBE 8			
CP22009	TBE	9150 / 9170 / 630 / 660 / 680 / 650	Original	635 540	5 TBE 8			
CP22022	TBG	Colhedeira 3640	Original	709 567	6 TBG 4			
CP22028	TBL		Especial		6 TBL 4			
CP22024	TBL	Colhedeira 220 / 310 / 1630	Original	720 560	5 TBL 4			
CP22025	TBL		Especial		7 TBL 4			
CP22026	TBG	Colhedeira 5650	Original	904 567	6 TBG 4			
CP22027	TBL		Especial		6 TBL 4			

## MF (AGCO) - RADIADORES

	TIPO		NÚMERO ORIGINAL	PADRÃO		CONSTR.
RP22000	TBE	65 X	1.482.063 / 1.482.317	Original	440 400	3 TBE 8
RP22008	TBL	299 - c/ Elemento de Óleo	ND	Original	476 510	6 TBL 8
RP22007	TBE	292 / 295 / 296	3.587.155-M91	Original	487 502	5 TBE 8
RP22004	TBE	265 / 275 / 285 / 290	2.801.211	Original	488 400	4 TBE 8
RO22031	TCU	Radiador Óleo 750	35.279.T1	Original	345 335	
RO22032	TCU	Radiador Óleo 680 / 950 / 970	20.362.T4 / 54.222.T4	Original	370 276	
RO22033	TCU	Radiador Óleo 650 / 660 / 680 - Advanced	54.522.T1	Original	370 276	
RO22034	TCU	Radiador Óleo 86	35.854.32-M91 / 35.278.T1	Original	402 285	



## MBB (CAMINHÕES) - COLMÉIAS

		TIPO	  	PADRÃO		CONSTR.	CAB.	
CP10084	TBE	180 D		Original	414	491	3 TBE 8	
CP10041 CP10001 CP10005 CP10004	CTM TBG TBE TBE	L 608 / L 708		Super Opcional Especial Original	420	560	2 CTM 14 4 TBG 8 4 TBE 8 3 TBE 8	
CP10075 CP10048 CP10020	CTM CTM TBE	L 1214 C / 1414 C / 712 C / 914 C / 1215 C / 610		Especial Original Super	451	623	3 CTM 14 2 CTM 14 4 TBE 8	Solda
CP10063 CP10037 CP10078	CTM TBE CTM	L 709 / 809 / 812 / 912 / 710		Original Opcional Especial	475	510	2 CTM 14 3 TBE 8 3 CTM 14	Solda
CP10062 CP10069 CP10051	CTM CTM TBE	L / LK 1214 / 2314		Original Especial Super	512	623	2 CTM 14 3 CTM 14 4 TBE 8	Solda
CP10012 CP10070 CP10053	CTY CTM TBE	L / LK 1620 96 > Intercooler / L / LK 1218 > 2318 / MKL 1214 > 2314		Original Especial Super	544	623	2 CTY 16 3 CTM 14 4 TBE 8	Solda
CP10013 CP10076	CTY CTM	L 914 Intercooler / 710 Plus		Original Especial	545	623	2 CTY 16 3 CTM 14	Solda
CP10135 CP10134	CTY CTY	Atego - Radiador Auxiliar Atego 1315 / 1418 / 1518 / 1718		Especial Especial	570 570	290 530	2 CTY 16 2 CTY 16	Solda Solda
CP10006	TBE	L 1116 / 2216		Especial	572	565	5 TBE 8	
CP10022	TBE	L 1114 / 2214		Especial	572	595	5 TBE 8	
CP10014	TBE	L 1924 A / L 1929		Turbinado	575	740	5 TBE 8	
CP10000 CP10002	TBE TBE	L 1113 / 2213		Original Especial	585	595	4 TBE 8 5 TBE 8	
CP10007 CP10009	TBE TBE	L 1117 / 2217 / LS 1519 / 2219		Original Especial	600	595	4 TBE 8 5 TBE 8	
CP10015 CP10066 CP10042	CTY CTM TBE	LS 1723 / L 1622 / L 2423 LS 2423 / 2428 L 2423 / 2428		Original Especial Canaveiro	617	623	2 CTY 16 3 CTM 14 4 TBE 8	Solda
CP10059 CP10096 CP10072	CTM CTM TBE	L 1214 / 1618 / 1621		Original Especial Super	660	641	2 CTM 14 3 CTM 14 4 TBE 8	Solda
CP10035 CP10068 CP10039	CTM CTM TBE	L 1214 / 1618 / 1621		Original Especial Super	660	658	2 CTM 14 3 CTM 14 4 TBE 8	Solda
CP10058 CP10011	CTM TBE	LS 1524 / 1525 / 2025 / 2225		Original Especial	665	590	3 CTM 14 5 TBE 8	
CP10073 CP10017	CTM TBE	LS 1932 / 1933 / 1934		Original Especial	665	766	3 CTM 14 5 TBE 8	
CP10085 CP10091 CP10089 CP10090	TBE CTM CTM TBE	Sprinter 310 / 312 / 410 / 412		Especial Original Original Especial	680	408	3 TBE 8 2 CTM 14 2 CTM 14 3 TBE 8	Grampo Grampo Solda Solda
CP10098 CP10114 CP10099 CP10115	CTM CTY CTM CTY	Axor 1933		Especial Original Especial Original	785	670	3 CTM 14 2 CTY 16 3 CTM 14 2 CTY 16	Solda Solda Grampo Grampo
CP10008 CP10055 CP10056	TBE CTY CTM	L 1621 / 1622 / 1721 - Intercooler Moderno		Super Original Especial	809	641	4 TBE 8 2 CTY 16 3 CTM 14	Solda
CP10054 CP10102 CP10050	TBE CTY CTM	L 1621 / 1622 / 1721 - Intercooler Moderno		Super Original Especial	809	658	4 TBE 8 2 CTY 16 3 CTM 14	Solda



## MBB (CAMINHÕES) - COLMÉIAS

		TIPO		PADRÃO		CONSTR.	CAB.
CP10060 CP10103 CP10046 CP10049	CTM CTY TBE TBE	LS 1625 / 1630 / 1633 / 1935 / 1941 / 2325 / 2635	Especial Original Canavieiro Betoneira	907	714	3 CTM 14 2 CTY 16 4 TBE 8 4 TBE 11	
CP10101 CP10116 CP10100 CP10117	CTM CTY CTM CTY	Axor 2035 / 2543 / 2640	Especial Original Especial Original	972	692	3 CTM 14 2 CTY 16 3 CTM 14 2 CTY 16	Solda Solda Grampo Grampo
CP10094	CTY	1938S / 1944S	Especial	975	670	2 CTY 16	Solda
CP10097 CP10105 CP10095	CTM CTY TBE	LS 1632 / 1634 / 1645 / 1938 / 2638	Especial Original Canavieiro	998	702	3 CTM 14 2 CTY 16 4 TBE 8	Solda
CP10064 CP10104 CP10047	CTM CTY TBE	LS 1935 / 1941 / 2635 - Moderno	Especial Original Canavieiro	1006	714	3 CTM 14 2 CTY 16 4 TBE 8	

## MBB (ÔNIBUS) - COLMÉIAS

		TIPO		PADRÃO		CONSTR.	CAB.
CP10048 CP10082 CP10075	CTM TBE CTM	OF 1417 / LO 914 / LO 610	Original Opcional Especial	451	623	2 CTM 14 3 TBE 8 3 CTM 14	Solda
CP10023 CP10024	TBE TBE	OF 1313 - Rebaixado	Original Especial	525	595	4 TBE 8 5 TBE 8	
CP10045 CP10088 CP10070	CTM TBE CTM	OF 1721	Original Opcional Especial	544	623	2 CTM 14 3TBE 8 3 CTM 14	Solda
CP10043 CP10013 CP10076	TBE CTY CTM	OF 814 / LO 710	Opcional Original Especial	545	623	3 TBE 8 2 CTY 16 3 CTM 14	
CP10108 CP10018 CP10109 CP10110	CTM CTM CTM CTM	O 500 / OH 1417	Original Especial Original Especial	560	660	2 CTM 14 3 CTM 14 2 CTM 14 3 CTM 14	Solda Solda Grampo Grampo
CP10025 CP10026	TBE TBE	OH 1313 / 362 / 364	Original Especial	595	595	4 TBE 8 5 TBE 8	
CP10016 CP10032	CTM TBE	O 371 / 370 R	Original Especial	600	634	3 CTM 14 5 TBE 8	
CP10038 CP10040 CP10066	CTM TBE CTM	OF 1722	Original Opcional Especial	617	623	2 CTM 14 3 TBE 8 3 CTM 14	Solda
CP10028	TBE	O 355H / O 326 / OH 1517 / O 364R / O 365R	Original	645	680	5 TBE 8	
CP10059 CP10036 CP10096	CTM TBE CTM	OH 1315 / 1318 / OF 1315 / 1317 / 1318 / 1620	Original Opcional Especial	660	641	2 CTM 14 3 TBE 8 3 CTM 14	Solda
CP10035 CP10061 CP10068	CTM TBE CTM	OH 1315 / 1318 / OF 1315 / 1317 / 1318 / 1620	Original Opcional Especial	660	658	2 CTM 14 3TBE 8 3 CTM 14	Solda
CP10010 CP10021 CP10106 CP10107	CTM CTM CTM CTM	O 500	Original Especial Original Especial	660	660	2 CTM 14 3 CTM 14 2 CTM 14 3 CTM 14	Solda Solda Grampo Grampo





## MBB (ÔNIBUS) - COLMÉIAS

		TIPO		PADRÃO		CONSTR.	CAB.
CP10034 CP10030	CTM TBE	O 371 / 370 RS	Original Especial	672	634	3 CTM 14 5 TBE 8	
CP10085 CP10091 CP10089 CP10090	TBE CTM CTM TBE	310 > 312 / 410 > 412	Especial Original Original Especial	680	408	3 TBE 8 2 CTM 14 2 CTM 14 3 TBE 8	Grampo Grampo Solda Solda
CP10031 CP10033	TBE CTM	O 371 / 370 RSD - Intercooler	Especial Original	742	694	5 TBE 8 3 CTM 14	Solda
CP10080 CP10086 CP10057	CTM CTM TBE	O 400	Especial Original Opcional	770	702	3 CTM 14 2 CTM 14 3 TBE 8	Solda
CP10111 CP10112 CP10113	CTM CTM TBE	OH 1620 / OH 1621 / OH 1420 - Plataforma	Especial Original Opcional	816	641	3 CTM 14 2 CTM 14 3 TBE 8	Solda
CP10079 CP10077 CP10074	CTM CTM TBE	OH 1620 / OH 1621 / OH 1420 - Plataforma	Especial Original Opcional	816	658	3 CTM 14 2 CTM 14 3 TBE 8	Solda
CP10081 CP10083 CP10087	CTM CTM TBE	O 400 - Intercooler	Especial Original Opcional	890	702	3 CTM 14 2 CTM 14 3 TBE 8	Solda
CP10065 CP10067 CP10071	CTM CTM TBE	O 400 - Plataforma	Especial Original Opcional	905	702	3 CTM 14 2 CTM 14 3 TBE 8	Solda
CP 10130 CP 10131 CP 10132 CP 10133	CTM CTM CTM CTM	O 500 Rodoviário	Original Especial Original Especial	925	660	2 CTM 14 3 CTM 14 2 CTM 14 3 CTM 14	Solda Solda Grampo Grampo

## MBB (ESTACIONÁRIO) - COLMÉIAS

		TIPO		PADRÃO		CONSTR.	CAB.
CP10146	CTM	OM 366	Original	730	702	3 CTM 14	Solda
CP12748	TBG	OM 447 A	Original	1000	1000	6 TBG 8	CF 25 X 3
CP12750	TBE	OM 447 LA	Original	1000	1000	6 TBE 8	CF 25 X 3



## MBB (CAMINHÕES) - RADIADORES

	TIPO	  	NÚMERO ORIGINAL	PADRÃO		CONSTR.
RP10084	TBE	L 180 D	631.500.07.02	Especial	414 491	3 TBE 8
RP10001	TBG	L 608 D / L 708 E	308.500.72.03	Original	420 560	4 TBG 8
RP10048	CTM	L 1214 C / 1414 C - Cara Chata	693.500.70.01	Original	451 623	2 CTM 14
RP10093	CTM	L 712 C / 914 C - Cara Chata	688.500.71.01	Original	451 623	2 CTM 14
RP10118	CTM	L 1215 C - Cara Chata / 610	693.500.73.01 688.500.00.01	Original	451 623	2 CTM 14
RP10078	CTM	LO 809 / 812 / 912 / 710	688.500.05.03	Original	475 510	3 CTM 14
RP10063	CTM	L 709 / LN 809	688.500.04.03	Original	475 510	2 CTM 14
RP10062	CTM	L / LK 1214 > 2314 - Cara Chata	674.500.20.03 682.500.70.03 682.500.73.03	Original Original Original	512 623	2 CTM 14
RP10012	CTY	L / LK 1620 96> intercooler	695.500.70.01	Original	544 623	2 CTY 16
RP10045	CTM	L / LK 1218 > 2318 - Cara Chata MKL 1214 > 2418 - Intercooler	677.500.15.03 682.500.71.03 682.500.75.03	Original	544 623	2 CTM 14
RP10013	CTY	L 914 intercooler / 710 Plus Intercooler 04 >	685.500.06.03 688.500.83.03	Especial	545 623	2 CTY 16
RP10022	TBE	L 1114 > 2214 L 1116 > 2216	364.501.82.01 364.501.79.01	Especial	572 595	5 TBE 8
RP10002	TBE	L 1113 > 2213 - Turbinado	045.500.00.04	Especial	585 595	5 TBE 8
RP10119	TBE	L 1117 > 2217 L 1118 > 2218	345.501.86.01 345.501.86.01	Especial	600 595	5 TBE 8
RP10009	TBE	LS 1519 > 2219	345.500.70.03	Especial	600 595	5 TBE 8
RP10066	CTM	2423 / 2428 - Cara Chata	693.500.00.01	Original	617 623	3 CTM 14
RP10015	CTY	LS 1723 L1622	693.500.72.01 695.500.72.01	Especial	617 623	2 CTY 16
RP10035	CTM	L / LK 1214 > 1618 L 1621 - Sem Intercooler	384.501.72.01 384.505.72.01	Original	660 658	2 CTM 14
RP10120	CTY	L 1621 - Intercooler	386.501.76.01	Especial	660 658	2 CTY 16
RP10011	TBE	LS 1524 / 1525 / 2025 / 2225	345.501.80.01	Especial	665 590	5 TBE 8
RP10017	TBE	LS 1932 / 1933 / 1934	350.500.74.03 350.500.77.03	Especial	665 766	5 TBE 8
RP10089	CTM	Sprinter 310	A901.500.33.00	Especial	680 408	2 CTM 14
RP10102	CTY	L 1621 moderno / L 1622 / 1721 LK 1614 / 1714 / 1718	386.501.78.01 386.501.70.03	Especial	809 658	2 CTY 16
RP10103	CTY	LS 1630 / 1633 / 1935 / 1941 / 2635	388.501.72.01 388.501.80.01 / 388.501.74.01	Original	907 714	2 CTY 16
RP10121	CTY	LS 1625 / L / LK 2325	386.501.73.01	Original	907 714	2 CTY 16
RP10094	CTY	1938S / 1944S	693.500.75.01	Especial	975 670	2 CTY 16
RP10122	CTY	LS 1632	695.500.71.01	Especial	998 702	2 CTY 16
RP10105	CTY	LS 1634 / 1645 LS 1938 / 2638	695.500.00.01 696.500.70.01	Especial	998 702	2 CTY 16
RP10104	CTY	LS 1935 / 1941 - Moderno	388.501.76.01 388.501.79.01	Original	1006 714	2 CTY 16



## MBB (ÔNIBUS) - RADIADORES





		TIPO		NÚMERO ORIGINAL	PADRÃO		CONSTR.
RP10118	CTM	LO 610 / 710		688.500.00.01	Original	451	2 CTM 14
RP10124	CTM	OF 1417 / LO 914		384.500.71.01	Original	623	2 CTM 14
RP10024	TBE	OF 1313 / 1315 - Rebaixado		344.500.70.03 / 345.501.72.01	Especial	525 595	5 TBE 8
RP10012	CTY	OF 1721		695.500.70.01	Original	544 623	2 CTY 16
RP10013	CTY	OF 814 Intercooler - LO 814		685.500.06.03	Original	544 623	2 CTY 16
RP10018	CTM	O 500 / OH 1417		A382.501.00.01	Especial	560	3 CTM 14
RP10021	CTM	O 500		A382.500.01.02	Especial	660	3 CTM 14
RP10130	CTM	O 500 - Rodoviário		A634.501.00.01	Especial	925 660	3 CTM 14
RP10015	CTY	OF 1722		695.500.72.01	Especial	617 623	2 CTY 16
RP10127	CTM	OF 1315 / 1317 / 1318		384.500.70.03	Original	660 658	2 CTM 14
RP10128	CTM	OF 1318 E / 1618 / 1620 / 1621 > 95 OF 1618 / 1620 96 > Intercooler		A684.500.70.03 384.500.75.03 / 384.500.81.03 384.500.73.03	Especial	660 658	2 CTM 14
RP10089	CTM	Sprinter 310 / 312 - Plataforma		A901.500.33.00	Especial	680 408	2 CTM 14
RP10086	CTM	O 400 - PL		664.501.77.01	Especial	770 702	2 CTM 14
RP10077	CTM	OH 1420		382.500.75.03	Especial		2 CTM 14
RP10123	CTM	OH 1620 - Plataforma		382.501.76.01	Especial	816 658	2 CTM 14
RP10125	CTM	OH 1621 - Plataforma		382.501.71.01	Especial		2 CTM 14
RP10083	CTM	O 400 - Intercooler (PL)		664.501.88.01	Especial	890 702	2 CTM 14
RP10129	CTM	O 400 - Intercooler (PP)		664.501.78.01	Especial		2 CTM 14

## MBB - INTERCOOLERS





		TIPO		NÚMERO ORIGINAL	PADRÃO		CONSTR.
IP 10239	AL	L / LK 1620 / OF 1721 / 1723 - C. Chata		384.501.83.01 / 695.501.70.01	Opcional	420 550	4 AL 8
IP 10833	AL	OF 1417 / 712C / 914C / 1215C / LO 610		688.501.71.01 / 688.501.01.01	Opcional	450 605	3 AL 8
IP 10769	AL	OH 1318 / 1418 / 1620		684.501.73.03	Opcional	532 614	3 AL 8
IP 10885	AL	OF 1620 / 1621 / 1318		384.501.79.01 / 80.01	Opcional	532 614	3 AL 8
IP 10154	AL	Atego		970.501.02.01	Opcional	570 530	4 AL 8
IP 10832	AL	L 1622 / OF 1722 / 2423 2428		695.501.00.01 693.501.73.01	Opcional	600 605	4 AL 8
IP 10343	AL	LS 1938 / 2638 LS 1634		696.501.70.01 695.501.04.01	Opcional	600 1010	4 AL 8
IP 10834	AL	L 914 / 710 Plus		685.500.00.01	Opcional	608 384	3 AL 8
IP 10270	AL	L 1113		Adaptação	Especial	620 305	3 AL 8
IP 10153	AL	OH 1621 - Plataforma		382.501.72.01 / 382.501.74.01	Opcional	673 490	3 AL 8
IP 10176	AL	LS 1935 / 2635 / 1941 / 1630		386.500.83.01	Opcional	697 590	4 AL 8
IP 10185	AL	L 1632		695.501.71.01	Opcional	697 650	3 AL 8
IP 10264	AL	L 1621		386.501.72.01	Opcional	700 495	3 AL 8
IP 10394	AL	310 / 312 Sprinter		A901.501.07.01	Opcional	720 250	2 AL 8
IP 10268	AL	O 370 / 371		364.501.74.01	Opcional	740 430	4 AL 8
IP 10318	AL	LS 1932 / 1933 / 1934		350.500.78.03 / 350.501.73.01	Opcional	740 430	4 AL 8
IP 10772	AL	O 400		664.501.79.01	Opcional	825 500	4 AL 8







## MICHIGAN - COLMÉIAS

 TIPO			  			PADRÃO	 A x L	CONSTR.	CAB.
CP13745	TBE	L 30	Original	589	598	5 TBE8			
CP13740	TBE	45 / 55 / 65 / 75 III	Original	618	610	5 TBE 8			
CP13743	TBE	55 C - Turbinado	Original	690	610	5 TBE 8			
CP13749	TBG	L 90	Original Reforçado	788	766	6 TBG 8			
CP13750	TBG								
CP13742	TBE	85 / 125	Original	887	678	6 TBE 8			
CP13751	TBG	125 C	Reforçado	935	870	7 TBG 8	CF		

## MICHIGAN - RADIADORES

 TIPO			  			NÚMERO ORIGINAL	PADRÃO	 A x L	CONSTR.
RP13740	TBE	45 / 55 C	3.303.802	Original	618	610	5 TBE 8		
RP13741	TBE	75 III - Motor Mercedes	3.301.333	Original	618	610	5 TBE 8		
RP13743	TBE	55 C - Turbo	12.707.457	Original	690	610	5 TBE 8		
RO13744	TCU	Radiador Óleo 55C - Conexões Retas	ND	Original	580	203			
RO13746	TCU	Radiador Óleo 55C - Conexões Curvas	12.706.816	Original	580	203			
RO13747	TCU	Radiador Óleo L90 - Flange	11.033.359	Original	680	135			



## MITSUBISHI - COLMÉIAS

 TIPO			  			PADRÃO	 A x L	CONSTR.	CAB.
CP24704	CTY	Pajero	Original	400	595	2 CTY 16	Solda		
CP24703	CTY	L 200	Original	422	605	2 CTY 16	Solda		
CP24707	CTY	L 200	Original	452	681	2 CTY 16	Solda		
CP24706	CTY	Pajero	Original	500	645	2 CTY 16	Solda		





## NISSAN - COLMÉIAS

 TIPO			  			PADRÃO	 A x L	CONSTR.	CAB.
CP24500	CTY	Frontier	Original	450	687	2 CTY 16	Solda		

## PERKINS - COLMÉIAS

 TIPO			  			PADRÃO	 A x L	CONSTR.
CP22000	TBE	3 Cil. - Estacionário	Original	440	400	3 TBE 8		
CP22040	TBG	6 Cil. - Estacionário	Original	620	630	4 TBG 8		
CP22041	TBG	4 / 6 Cil. - Estacionário	Original	640	630	4 TBG 8		

## PERKINS - RADIADORES

 TIPO			  			NÚMERO ORIGINAL	PADRÃO	 A x L	CONSTR.
RP22039	TBE	3 Cil. - Estacionário s/ Defletor	75.023	Original	440	400	3 TBE 8		
RP22040	TBG	4 / 6 Cil. - Estacionário s/ Defletor	75.018 / 75.013	Original	620	630	4 TBG 8		



## PEUGEOT - COLMÉIAS

TIPO			PADRÃO			CONSTR.		CAB.
CP24580	TBE	504 Diesel	Especial	600	390	2 TBE 11		
CP13020	CTM	Boxer 2.5 / 2.8 D / TD	Especial	790	410	2 CTM 14		Solda
CP13017	CTM	Boxer 2.5 D / TD AC	Especial	1000	410	2 CTM 14		Solda

## PEUGEOT - RADIADORES

TIPO			NÚMERO ORIGINAL		PADRÃO		CONSTR.		CAB.
RP13020	CTM	Boxer 2.5 / 2.8 TD	1.331.792.080 / 1.307.395.080		Especial	790	410	2 CTM 14	94 >
RP13017	CTM	Boxer 2.5D / TD AC	1.311.521.080		Especial	1000	410	2 CTM 14	> 01

## RENAULT - COLMÉIAS

TIPO			PADRÃO			CONSTR.		CAB.
CP24553	TBE	Traffic - Gasolina / Diesel	Opcional	630	330	2 TBE 11		
CP24550	CTY		Original	730	415	2 CTY 16		
CP24551	CTY	Master	Original	730	415	2 CTY 16		Solda

## RENAULT - RADIADORES

TIPO			NÚMERO ORIGINAL		PADRÃO		CONSTR.		CAB.
RP24550	CTY	Traffic - Gasolina	7.702.093.794		Original	630	330	2 CTY 16	89 / 97
RP24552	CTY	Traffic - Diesel	7.702.094.077						

## SCÂNIA (CAMINHÕES) - COLMÉIAS

TIPO			PADRÃO		CONSTR.		CAB.	CAB.	
CP15002	TBE	L 110	Especial Super	610	710	5 TBE 8	117	61 / 76	
CP15003	TBE			6 TBE 8					
CP15006	TBE	L 111	Especial Super	617	772	5 TBE 8	102	76 / 83	
CP15007	TBE			6 TBE 8					
CP15033	CTM	T 112 / 113	Original	718	775	3 CTM 14	96	84 / 98	
CP15036	CTM	R 142 / 143 - Intercooler	Original	718	1028	3 CTM 14	96	84 / 98	
CP15010	TBE	LK 111 / 140 / 141	Especial	790	774	5 TBE 8	102	76 / 83	
CP15004	CTY	P 94 / 124 - Série 4	Original	860	710	2 CTY 16	Grampo	94 / 07	
CP15000	CTY					2 CTY 16			72
CP15035	CTM					3 CTM 14			72
CP15005	CTY	R / T 114 / 124 - Série 4	Original	860	931	2 CTY 16	Grampo	94 / 07	
CP15001	CTY					2 CTY 16			72
CP15034	CTM					3 CTM 14			72
CP15016	CTM	T 112 / 113 / 142 / 143 - Intercooler	Original	975	775	3 CTM 14	96	84 / 98	



## SCÂNIA (CAMINHÕES) - RADIADORES

		TIPO		NÚMERO ORIGINAL	PADRÃO		CONSTR.	
RP15006	TBE	L 111		231.811	Especial	617 775	5 TBE 8	76 / 83
RP15033	CTM	T 112 / 113 / R142		334.840 / 526.301 / 1.100.630 / 310.080	Especial	718 775	3 CTM 14	84 / 98
RP15036	CTM	R 142 / 143 - Intercooler		334.842 / 526.303 / 310.082	Original	718 1028	3 CTM 14	84 / 98
RP15000	CTY	P 94 / 124 - Série 4		1.439.504	Especial	860 710	2 CTY 16	94 / 07
RP15001	CTY	R / T 114 / 124 - Série 4		1.442.751 / 1.397.435	Especial	860 931	2 CTY 16	94 / 07
RP15016	CTM	T 112 / 113 - Intercooler		334.841 / 526.302 / 1.100.631 / 310.081	Especial	975 775	3 CTM 14	84 / 98

## SCÂNIA (ÔNIBUS) - COLMÉIAS

		TIPO		PADRÃO		CONSTR.	CAB.
CP15020	TBE	B 75 / 76 / 110 / 111 / BR 115		Original	615	605	4 TBE 8
CP15021	TBE			Especial			5 TBE 8
CP15022	TBE	BR 116		Original	708	775	4 TBE 8
CP15023	TBE			Especial			5 TBE 8
CP15029	TBE	K 112 / 113 - s/ Laterais		Especial	718	772	5 TBE 8
CP15032	CTM			3 CTM 14			
CP15030	TBE			5 TBE 8			
CP15025	CTY	F 94 / K 124 série 4 - c/ Laterais		Original	860	710	2 CTY 16
CP15045	CTM			Especial			3 CTM 14

## SCÂNIA (ÔNIBUS) - RADIADORES

		TIPO		NÚMERO ORIGINAL	PADRÃO		CONSTR.	
RP15033	CTM	S 112 / F 112		334.840 / 526.301 / 1.100.630 / 310.080	Especial	718 772	3 CTM 14	84 / 98
RP15030	TBE	K 112 / 113		525.950	Especial	718 772	5 TBE 8	84 / 98
RP15000	CTY	F 94 / K 124 - Série 4		1.439.504	Especial	860 710	2 CTY 16	94 / 07

## SCÂNIA (MOTORES) - COLMÉIAS

		TIPO		PADRÃO		CONSTR.
CP15009	TBE	D 11		Original	743 707	4 TBE 8
CP15008	TBE	DS 11 A 06		Original	790 774	4 TBE 8
CP15027	TBE	DS 14 A-01 / DS 14 A 03		Original	975 1028	4 TBE 8
CP15026	TBE	DS 14		Original	994 1006	4 TBE 8
CP15037	TBE	DSC 58A		Original	1210 1002	4 TBE 8

## SCÂNIA (MOTORES) - RADIADORES

		TIPO		NÚMERO ORIGINAL	PADRÃO		CONSTR.
RP15008	TBE	DS 11 A-06		530.473	Original	790 774	4 TBE 8
RP15027	TBE	DS 14		526.304	Original	975 1028	4 TBE 8
RP15026	TBE	DS14 A-01 / DS 14 A-03		238.966 / 524.434	Especial	994 1006	4 TBE 8



## SCÂNIA - INTERCOOLERS

		TIPO		NÚMERO ORIGINAL	PADRÃO		CONSTR.
IP15652	AL	SCANIA 112 / 142 / 113 / 143		524.305 / 1.100.086	Opcional	672 650	4 AL 8
IP15186	AL	SCANIA R / T 114 / 124		1.408.882 / 1.384.059 / 1.477.051 1.510.014 / 1.516.492	Opcional	828 790	4 AL 8

## TEREX - COLMÉIAS

		TIPO		NÚMERO ORIGINAL	PADRÃO		CONSTR.	CAB.
CP16400 CP16401	TBG TBC	TS 14		9.028.729	Original Reforçado	710 730	5 TBG 8 5TBC 8	CF
CP16408 CP16409	TBG TBC	R 22 - Motor Cummins		9.391.985	Original Reforçado	795 915	6 TBG 8 6 TBC 8	CF
CP16402 CP16403	TBG TBC	TS 460		9.392.289	Original Reforçado	913 980	7 TBG 8 7 TBC 8	CF
CP16410 CP16411	TBE TBE	7251		9.236.027	Original Reforçado	927 748	5 TBE 8	CF
CP16412 CP16413	TBG TBC	7252		9.060.325	Original Reforçado	1016 820	6 TGB 8 6 TBC 8	CF
CP16404 CP16405	TBG TBC	TS 24		9.205.695	Original Reforçado	1016 1205	6 TBG 8 6 TBC 8	CF
CP16406 CP16407	TBG TBC	R 35 / S 24		9.373.134 / 9.028.437 / 9.385.801	Original Reforçado	1016 1205	7 TBG 8 7 TBC 8	CF

## TOYOTA - COLMÉIAS

		TIPO		PADRÃO		CONSTR.	CAB.	
CP12900 CP12915 CP12902 CP12901 CP12918 CP12903	TBE TBE TBE TBE TBE TBE	Jeep / Pick-up Bandeirante - Motor MB		Original Opcional Especial Original Opcional Especial	435 495	3 TBE 8 4 TBG 8 4 TBE 8 3 TBE 8 4 TBG 8 4 TBE 8	90 / 75 90 / 75 90 / 75 75 75 75	> 93
CP12904 CP12905	CTM CTM	Jeep / Pick-up Bandeirante - Motor Toyota		Original Original	465 500	3 CTM 14	63 75	94 >
CP12909	CTM	Hilux 4 x 2		Original	480 530	3 CTM 14	Solda	92 / 01
CP12895 CP12899 CP12897	TBE TBE TBE	Empilhadeira FG 25		Especial Especial Especial	502 430	4 TBE 8	Solda 70 x 465 Solda 85 x 455 Grampo	
CP12898 CP12896	TBE TBE	Empilhadeira FG 40		Especial Especial	524 450	4 TBE 8	Solda Grampo	
CP12803 CP12906	CTY CTY	Hilux SRV 3.0 - 4 x 4 Turbodiesel Intercooler		Original Original	525 654	2 CTY 16	Solda Grampo	06 >
CP12800 CP12908	CTY CTY	Hilux SRV 3.0 4 x 2 - Gasolina / Diesel		Original Original	550 540	2 CTY 16	Solda Grampo	02 / 05
CP12801 CP12907	CTY CTY	Hilux SRV 3.0 4 x 4 - Gasolina / Diesel		Original Original	575 540	2 CTY 16	Solda Grampo	02 / 05
CP12802 CP12910	CTY CTY	Hilux SW4 3.0 Turbodiesel		Original Original	575 642	2 CTY 16	Solda Grampo	02 / 05



## TOYOTA - RADIADORES

		TIPO		NÚMERO ORIGINAL	PADRÃO		CONSTR.		
RP12901	TBE	Jeep / Pick-up Bandeirante		16.400.98.002	Original	435	495	3 TBE 8	
RP12903	TBE			16.400.98.005	Especial	435	495	4 TBE 8	> 93
RP12905	CTM	Jeep / Pick-up Bandeirante		16.400.374-T	Original	435	495	3 CTM 14	94 >
RP12909	CTM	Hilux 4 x 2		ND	Especial	480	530	3 CTM 14	92 / 01
RP12803	CTY	Hilux SRV 3.0 4 x 4 - Turbo Diesel Intercooler - s/ Lateral		BC422133-1002	Especial	525	654	2 CTY 16	06 >
RP12800	CTY	Hilux SRV 3.0 4 x 2 - Diesel		ND	Original	550	540	2 CTY 16	02 / 05
RP12804	CTY								
RP12801	CTY	Hilux SRV 3.0 4 x 4 - Diesel		ND	Original	575	540	2 CTY 16	02 / 05
RP12805	CTY								
RP12802	CTY	Hilux SW4 3.0 - Turbo Diesel		ND	Original	575	642	2 CTY 16	02 / 05

## VW - COLMÉIAS

		TIPO		PADRÃO		CONSTR.	CAB.		
CP14016	TBE	6-80 / 6-90 / 7-90 S		Original	440	598	3 TBE 8	70 x 618	80 / 87
CP14017	TBE			Especial	440	598	4 TBE 8		
CP14014	TBE	6-80 / 6-90 / 7-90 S		Original	440	619	3 TBE 8	100 x 626	80 / 87
CP14015	TBE			Especial	440	619	4 TBE 8		
CP14018	CTM	7-100		Original	440	623	2 CTM 14	65 x 640	94 >
CP14034	CTM	8-140		Especial	440	623	3 CTM 14	65 x 626	94 >
CP14045	CTM	8-140		Original	440	623	2 CTM 14	60 x 626	
CP14024	CTM	8-140		Original	445	615	2 CTM 14	65 x 640	94 / 00
CP14025	CTM			3 CTM 14					
CP14001	TBE			3 TBE 8					
CP14002	TBE			4 TBE 8					
CP14069	CTY	8-140 / 12-140 T / L-80		Original	465	615	2 CTY 16	65 x 626	94 / 00
CP14070	CTM			3 CTM 14					
CP14071	TBE			3 TBE 8					
CP14072	TBE			4 TBE 8					
CP14046	CTY	8-140 / 12-140 T / L-80		Original	465	623	2 CTY 16	65 x 640	94 / 00
CP14048	CTM			3 CTM 14					
CP14006	TBE			3 TBE 8					
CP14009	TBE			4 TBE 8					
CP14023	CTY	Kombi Diesel / Carajas		Original	480	345	2 CTY 16		Todos
CP14012	TBE	11 / 13 / 14-130 - 11 / 12 / 14-140 - 22-160		Original	498	598	3 TBE 8	70 x 618	> 90
CP14013	TBE			4 TBE 8					
CP14028	CTY	8-150 / 13-150		Original	500	602	2 CTY 16	65 x 626	00 >
CP14029	CTM			3 CTM 14					
CP14030	TBE			3 TBE 8					
CP14031	TBE			4 TBE 8					
CP14043	CTY	8-150 / 13-150		Original	500	602	2 CTY 16	87 x 626	00 >
CP14059	CTM			3 CTM 14					
CP14054	TBE			3 TBE 8					
CP14055	TBE			4 TBE 8					
CP14010	TBE	11 / 13 / 14-130 - 11 / 12 / 14-140 - 22-160		Original	500	619	3 TBE 8	100 x 626	> 90
CP14011	TBE			4 TBE 8					
CP14027	CTM	7-110		Especial	500	623	3 CTM 14	100 x 626	87 / 94
CP14047	CTY	8-150 / 13-150		Original	500	623	2 CTY 16	65 x 640	00 >
CP14057	CTM			3 CTM 14					
CP14040	TBE			3 TBE 8					
CP14041	TBE			4 TBE 8					
CP14093	CTM	Constellation 13-180 E / 15-180 E		Original	549	430	3 CTM 14	Solda	08 >





## VW - COLMÉIAS

		TIPO		PADRÃO		CONSTR.	CAB.	
CP14073 CP14074	CTM CTM	13 / 14 / 15 / 16-120 / 14-210 / 22-210	Especial	570	592	3 CTM 14	100 x 626 90 x 618	> 90
CP11046 CP11067 CP11072 CP11055	CTM CTM TBE TBE	16-180 - Ônibus Urbano	Original Especial Opcional Super	640	623	2 CTM 14 3 CTM 14 3 TBE 8 4 TBE 8	72 x 640	91 / 96
CP11069 CP11066 CP11042 CP11041	CTM CTM TBE TBE	16-180 - Ônibus Urbano / 11-140 / 14-150 / 14-200	Original Especial Opcional Super	640	634	2 CTM 14 3 CTM 14 3 TBE 8 4 TBE 8	90 x 655	91 / 96
CP11045 CP11065 CP11068	CTM CTM TBE	16-170 / 16-220 / 24-220 / 24-200	Original Especial Betoneira	706	623	2 CTM 14 3 CTM 14 4 TBE 8	72 x 640	91 / 93 98 / 00
CP11051 CP11054	CTM CTM	16-170 / 16-220 / 24-220 / 24-200	Especial Original	706	634	3 CTM 14 2 CTM 14	105 x 655	91 / 93
CP11061 CP11064 CP11080	CTM CTM TBE	16-170 / 16-220 / 24-220 / 24-200	Original Especial Betoneira	706	634	2 CTM 14 3 CTM 14 4 TBE 8	90 x 655	91 / 93 98 / 00
CP14058 CP14061 CP14064	CTM CTM TBE	16-210 - Ônibus Beta	Especial Original Opcional	737	623	3 CTM 14 2 CTM 14 3 TBE 8	72 x 640	97 >
CP11059 CP11063 CP11077 CP11084	TBE CTM CTM TBE	26-300 / 40-300 / 35-300 - Intercooler	Canavieiro Especial Original Betoneira	746	623	4 TBE 8 3 CTM 14 2 CTM 14 4 TBE 8	72 x 640	94 >
CP11085 CP11062 CP11079 CP11073	TBE CTM CTM TBE	26-300 / 40-300 / 35-300 - Intercooler	Canavieiro Especial Original Betoneira	746	634	4 TBE 8 3 CTM 14 2 CTM 14 4 TBE 8	90 x 655	94 >
CP14084	CTY	Constellation 13-180 / 24-250	Original	768	660	2 CTY 16	Solda	08 >
CP14063 CP14079 CP14052 CP14044	CTM CTY TBE TBE	18-310 / 24-220 / 24-250 / 26-300 / 40-300	Especial Original Canavieiro Betoneira	796	623	3 CTM 14 2 CTY 16 4 TBE 8 4 TBE 8	72 x 640	00 >
CP14062 CP14076 CP14066 CP14065	CTM CTY TBE TBE	18-310 / 24-220 / 24-250 / 26-300 / 40-300	Especial Original Canavieiro Betoneira	796	634	3 CTM 14 2 CTY 16 4 TBE 8 4 TBE 8	90 x 655	00 >
CP14085	CTM	Constellation 19-320 / 31-320 Tractor	Original	903	660	3 CTM 14	Solda	08 >

## VW - RADIADORES

		TIPO		NÚMERO ORIGINAL	PADRÃO		CONSTR.	
RP14019 RP14020	TBE	VW Aquecimento - Mangueiras Retas VW Aquecimento - Mangueiras Curvas	ND ND	Especial	195	120	2 TBE 11	> 02 03 >
RP14016	TBE	6-80 / 6 / 7-90 S	T06.121.253-A	Original	440	619	3 TBE 8	Todos
RP14024	CTM	8-140	2RD.121.253-A	Original	445	623	2 CTM 14	
RP14018	CTM	7-100	TAP.121.253-A 2RO.121.253-B	Original	445	623	2 CTM 14	Todos
RP14069	CTY	12-140 T	2RG.121.253-H	Original	465	615	2 CTY 16	Todos
RP14026	CTY	8-120 8-120 / 140 / L80 8-120	2VC.121.253 2RE.121.253 2RO.121.253-A	Original	465	615	2 CTY 16	00 > 97 / 99 01 >
RP14042	CTY	13-150	2SO.121.253	Original	500	623	2 CTY 16	> 00
RP14028	CTY	8-150	2VD.121.253	Original	500	623	2 CTY 16	01 >



## VW - RADIADORES

	TIPO		NÚMERO ORIGINAL	PADRÃO		CONSTR.	
RP14010	TBE	11 / 13-130 / 11 / 12 / 14 / 22-140 11 / 22-160 A	T11.121.253-B / C T2D.121.253	Original	500	623	3 TBE 8 > 90
RP14074	CTM	13 / 14 / 15 / 16 / 22-210 - Turbo Cummins	TE3.121.253-A	Original	570	592	3 CTM 14 Todos
RP11046	CTM	16-180 - Ônibus Urbano	2RP.121.253-B	Original	640	623	2 CTM 14 95 / 96
RP11069	CTM	16-180 - Ônibus Urbano	TAR.121.253	Original	640	634	2 CTM 14 93 / 94
RP11088	CTM	14-150 12-140 / 14-150	2RG.121.253-J TEG.121.253	Original	640	634	3 CTM 14 98 / 00 91 / 98
RP11061	CTM	14 / 16-170 / 14-220 / 16-200  16 / 24-220 / 35-300 - Intercooler	2SU.121253-A TRG.121.253 TMJ.121.253 2RG.121.253 2RL.121.253 2RK.121.253 2RN.121.253	Original	706	623	2 CTM 14 91 / 99
RP14037	CTM	12 / 15-170 17-210 / 24-250 12-170 / 14-220 / 17-210 14-220	2VG.121.253 2SO.121.253-A 2RN.121.253-A 2RK.121.253-A / B / D	Original	706	634	2 CTM 14 01 > 92 / 99 92 / 99 91 / 00
RP14038	CTM	17-210 - MWM	2VR.121.253-A	Original	706	634	2 CTM 14 01 >
RP14039	CTM	17-210 - Cummins	2VP.121.253 2TO.121.253-C 2VO.121.253-A	Original	706	634	2 CTM 14 01 > 00 >
RP14078	CTM	13 / 15-180	2VH.121.253	Original	706	634	2 CTM 14 > 01
RP14061	CTM	16-170 / 16-180 / 16-210 / 16-220 - Ônibus Beta	2WO.121.253 2RP.121.253-C 2TJ.121.253-B	Original	737	623	2 CTM 14 Todos
RP11100	CTM	16-220 16 / 35 / 40-300	2VC.121.253-A 2VC.121.253 2TG.121.253 2TC.121.253 2RT.121.253-A	Original	746	623	2 CTM 14 99 / 00 94 >
RP14036	CTM	17-220 MWM 6.10 TCA	2TO.121.253-E 2VR.121.253	Original	746	623	2 CTM 14 00 > 01 >
RP14084	CTY	Constellation 13-180 / 24-250	2V2.121.253-C	Original	768	660	2 CTY 16 08 >
RP14079	CTY	17-300 / 18-310 / 26-300 / 40-300	2TO.121.253-F 2VT.121.253-A 2TG.121.253	Original	796	623	2 CTY 16 01 > 00 > > 99
RP14088	CTY	26-260E	2U0.121.253-C	Original	796	623	2 CTY 16 08 >
RP14077	CTM	17-240 - Ônibus Proteus MWM 6-10 TCA	2TB.121.253-A / E	Original	816	658	2 CTM 14 Todos
RP14085	CTM	Constellation 19-320 / 31-320 Tractor	2T2.121.253-F 2T2.121.253-N	Original	903	660	3 CTM 14 08 >

## VW - INTERCOOLERS

	TIPO		NÚMERO ORIGINAL	PADRÃO		CONSTR.	
IP 14953	AL	VW - Leve	2RE.117.249	Opcional	568	376	3 AL 8 96 >
IP 14977	AL	VW 16180/ 16210 - Ônibus Beta	2RP.121.249-A	Opcional	580	540	3 AL 8 95 >
IP 14824	AL	VW - Pesado	2RT.117.249-A	Opcional	588	627	3 AL 8 91 >



## VALMET - VALTRA - COLMÉIAS

		TIPO		PADRÃO	 A x L		CONSTR.	CAB.
CP22784	TBE	BF 75		Original	399	498	6 TBE 8	
CP22770	TBE	60 / 80 / 85 ID / 600 D		Original Económico Especial Económico	428	444	4 TBE 8	Deslocada
CP22785	TBG						4 TBG 8	
CP22771	TBE						5 TBE 8	
CP22781	TBG						5 TBG 8	
CP22773	TBE	110		Original	453	525	5 TBE 8	
CP22776	TBE	68 - Cafeeiro 88 / 785		Original	468	442	3 TBE 8	Deslocada
CP22772	TBE			Original	468	442	4 TBE 8	
CP22778	TBE	980		Especial	512	590	4 TBE 8	
CP22777	TBE	880 / 885 / BM 85 / BM 100		Original	520	515	5 TBE 8	
CP22779	TBE	1180 4x4		Original	520	590	4 TBE 8	
CP22774	TBE	118 / 118.4 / 128 / 128.4		Original	583	518	5 TBE 8	
CP22783	TBE	985 / 1180 / 1280		Original	592	545	6 TBE 8	
CP22780	TBE	1280 / 1380 / 1580 / 1680 / 1780 / 1880 / BH 80		Económico Original	625	540	5 TBE 8	
CP22782	TBE						6 TBE 8	
CP22775	TBE	138 / 138.4 / 148.4 / 148 - Turbo		Original	655	518	5 TBE 8	

## VALMET - VALTRA - RADIADORES

		TIPO		NÚMERO ORIGINAL	PADRÃO	 A x L		CONSTR.
RP22785	TBG	65 ID		190.932 / 2Y.12751	Original	428	444	4 TBG 8
RP22781	TBG	85 ID		150.932	Original	428	444	5 TBG 8
RP22772	TBE	68 / 88		240.920 / 240.930 / 231.330	Original	468	444	4 TBE 8
RP22777	TBE	880 / 885 / BM 85 / BM 100		802.007	Original	520	515	5 TBE 8
RP22774	TBE	118 / 118.4 / 128 / 128.4		193.100	Original	583	518	5 TBE 8
RP22783	TBE	985 / 1180 / 1280		800.19.01	Original	592	545	6 TBE 8
RP22782	TBE	1280 / 1380 / 1580 / 1680 / 1780 / 1880 / BH 80		820.631.00 / 807.392.10	Original	625	540	6 TBE 8
RO22800	AL	Radiador Óleo - Trator		325.909.00	Especial	285	180	
RO22799	TCU	Radiador Óleo - 1280		807.393.10	Original	418	284	



## VOLVO - COLMÉIAS

		TIPO		PADRÃO		CONSTR.	CAB.	
CP13500	TBE	B 58		Original	535	670	4 TBE 8	80 / 87
CP13568 CP13571 CP13562	CTM CTY TBE	B 10 M / B 58 E		Especial Original Opcional	700	675	3 CTM 14 2 CTY 16 3 TBE 8	93 / 98
CP13574 CP13573 CP13575 CP13576	CTM CTY CTM CTY	VM - 260 / 310		Especial Original Especial Original	710	570	3 CTM 14 2 CTY 16 3 CTM 14 2 CTY 16	Solda Solda Grampo Grampo 06 >
CP13569 CP13570 CP13506 CP13507	CTM CTY CTM CTY	VM - 210 / 240		Especial Original Especial Original	720	570	3 CTM 14 2 CTY 16 3 CTM 14 2 CTY 16	Solda Solda Grampo Grampo 03 >
CP13567 CP13572 CP13558	CTM CTY TBE	B 10 M		Especial Original Opcional	805	675	3 CTM 14 2 CTY 16 3 TBE 8	99 >
CP13566	CTM	N 10 / 12		Original	850	660	3 CTM 14	Deslocada 80 / 87
CP13563	CTM	N 10 / 12 - Intercooler		Original	850	675	3 CTM 14	Centro 87 / 89
CP13509 CP13564	CTY CTM	B7 R / B12 B - Ônibus NL 10 / 12 - Intercooler		Opcional Original	880	675	2 CTY 16 3 CTM 14	Centro 94 / 98
CP13560 CP13561 CP13505 CP13503	CTM CTY CTM CTY	FM 10 - 380 / 440		Especial Original Especial Original	900	741	3 CTM 14 2 CTY 16 3 CTM 14 2 CTY 16	Solda Solda Grampo Grampo 01 >
CP13565 CP13501 CP13504 CP13559	CTM CTY CTM CTY	FH 12 / NH 12 - Globetrotter		Especial Original Especial Original	900	890	3 CTM 14 2 CTY 16 3 CTM 14 2 CTY 16	Solda Solda Grampo Grampo 99 >

## VOLVO - RADIADORES



		TIPO		NÚMERO ORIGINAL	PADRÃO		CONSTR.	
RP13571	CTY	B 10 M / B 58 E		8.365.791 / 1.191.000	Original	700	675	2 CTY 16 93 / 98
RP13573 RP13570	CTY CTY	VM - 260 / 310 VM - 210 / 240		20.810.091 20.540.099	Especial Especial	710 720	570 570	2 CTY 16 06 > 2 CTY 16 03 >
RP13572	CTY	B 10 M		8.196.442	Original	805	675	2 CTY 16 99 >
RP13563	CTM	N 10 / 12 - Intercooler		6.886.550	Original	850	675	3 CTM 14 87 / 89
RP13564	CTM	B7 R / B12 B NL 10 / 12 - Intercooler		8.120.680	Original Original	880	675	3 CTM 14 99 > 90 / 98
RP13561 RP13502	CTY	FM 10 - 380 FM 440 - c/ Pino p/ coxim		8.149.370 20.722.444	Especial	900	741	2 CTY 16 01 / 05 06 >
RP13501 RP13508	CTY	FH 12 / NH 12 - Globetrotter FH 380/ 400/ 420 Globetrotter - c/ Pino p/ coxim		8.149.362 20.722.440	Especial	900	890	2 CTY 16 99 / 05 06 >

## VOLVO - INTERCOOLER



		TIPO		NÚMERO ORIGINAL	PADRÃO		CONSTR.	
IP13651	AL	N 10 / 12		1.544.468	Opcional	849	658	4 AL 8 Todos
IP13650	AL	NL 10 / 12		1.676.590 / 1.664.585	Opcional	877	630	4 AL 8 Todos
IP13656	AL	B 7R		8.196.008 / 20.439.849	Opcional	877	630	4 AL 8 Todos
IP13694	AL	NH / FH 12		1.676.633 / 817.452-R	Opcional	885	910	4 AL 8 Todos



## YALE - COLMÉIAS

		TIPO		PADRÃO	 A x L	CONSTR.	
CP12370	TBG	5.057.536 / 5.079.276 / 7.100.195		Original	450	495	4 TBG 8
CP12732	TBE			Especial			4 TBE 8
CP12371	TBE	134 A		Original	660	598	5 TBE 8

## YANMAR - COLMÉIAS

		TIPO		PADRÃO	 A x L	CONSTR.	CAB.	
CP12503	TBG	Motor NS50C		Original	126	165	6 TBG 8	CF
CP12506	TBG	Micro Motor TC 12 / TC 14 / TC 14S		Original	144	207	6 TBG 8	CF
CP12505	TBG	Motor NS18R		Original	165	207	6 TBG 8	CF
CP12550	TBE	1145-4 / 1155-4 / 1145-4 CAFEIRO 4X4		Original	415	380	3 TBE 8	Solda
CP12552	TBE			4 TBE 8				
CP12600	TBE	1030-H - Cafeeiro 4X2		Original	435	394	3 TBE 8	Solda
	TBE	1030-D - 4X4						
CP12601	TBE	1050-D Turbo 4X4		Original	476	394	4 TBE 8	Solda
CP12551	TBE	1175		Original	550	500	5 TBE 9	Solda
CP12556	TBE	1175 - Super Redução					6 TBE 9	







*Rua Madalena Madureira, 151*  
*CEP 02551-040 - São Paulo - SP*  
*Telefone (Vendas): 0xx11 3856.6440*  
*E-mail: vendas@radiadorespinguim.com.br*  
*www.radiadorespinguim.com.br*